

High Performance Inverters
FRENIC-Ace Series



New Standard
FRENIC-Ace
[OUTPUT : 0.1 - 22kW]

The FRENIC-Ace is the inverter that produces excellent cost-performance;
maintains high performance through optimal design.
In this way, it can be applied to various machines and devices.

DRIVE THE NEXT

Since launching in 1992, Fuji's high-performance standard-type inverters have continued to evolve with the times. They strive to meet future market needs through cultivated and reliable inverter technologies.

► **Evolution history** (High-performance standard-type inverters) Representative models: 3-phase 200 V series 0.75 kW

1992

FVR-E7S

Original model of high-performance standard types



1995

FVR-E9S

Torque vector control, Foreign standards compliant



1999

FVR-E11S

Automatic energy saving, PID control and other intelligent functions





FRENIC-Ace | E3

SERIES

2005

**FRENIC-Multi
(FRN-E1)**

EMC filter, Enhanced networking



2014

**FRENIC-Ace
(FRN-E2)**

Customizable logic functions, Two load ratings



2023

**FRENIC-Ace
(FRN-E3)**



Evolving with the times.

The power of the industry's new leading standard.

Inherits and enhances the basic specifications of the E2 Series.

Pursuing maximum performance in the smallest class of inverter body. New finless type and Ethernet type have been added to the product lineup.

Enjoy better user-friendliness and performance than ever before.

High basic performance

Provides a full range of motor control and enhanced functionality.

Supports a wide variety of networks to realize IoT.

FRENIC-Ace

E3

SERIES

Extensive lineup

Lineup of 4 types for each power supply voltage.

Supports a wide range of applications from light loads to heavy loads.

Easy maintenance

Easy wiring and setup, as well as remote control, for improved work efficiency.

Provides preventive and predictive maintenance functions to ensure safety.



CONTENTS

» Features		» Standard specifications		» Keypad functions	46
High basic performance	06	Three-phase 200 V series	18	» Keypad operation	47
Extensive lineup	08	Three-phase 400 V series	20	» Function codes	56
Easy maintenance	10	Single-phase 200 V series	23	» Options	71
» Main application examples	14	» Common specifications	26	» Product warranty	82
» Model variations	16	» Terminal features	34		
» How to read the inverter modelerter model	17	» Basic wiring diagram	36		
		» External dimensions	38		



High basic performance

Provides a full range of motor control and enhanced functionality.
Supports a wide variety of networks to realize IoT.

01 Faster operating speeds

Increases the maximum output frequency of all control systems to 599 Hz and supports applications that require high-speed rotation and minimal speed and torque fluctuations.

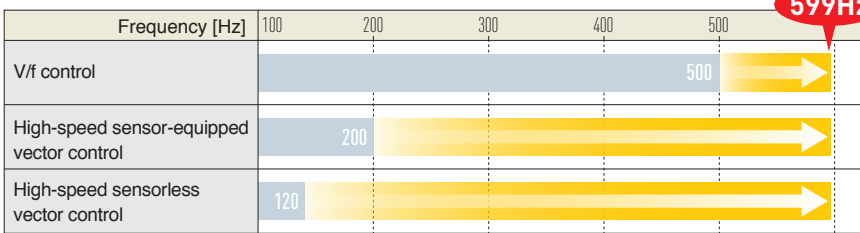

Note) Due to revised export control regulations (for frequency converters), the inverter will trip when the output frequency exceeds the upper limit of 599 Hz.



Example Machine tools, compressors, etc.

02 Can be used with any motor

Improves speed control range to stabilize torque at low speeds. Enables multi-drive with our induction and synchronous motors, as well as other company motors.

Speed control range

Motor Type	Control Method	Minimum speed	Constant torque region	Base speed	Constant output region
		Induction motor	1:20	1:2	Base speed
Induction motor	V/f control	1:20	1:2	Base speed	Constant output region
	During sensor-equipped V/f control*	1:20	1:2	Base speed	Constant output region
	Dynamic torque vector control	1:200	1:2	Base speed	Constant output region
	During sensor-equipped Dynamic torque vector control*	1:200	1:2	Base speed	Constant output region
	During sensorless vector control NEW	1:200	1:2	Base speed	Constant output region
	During sensor-equipped vector control*	1:1500	1:2	Base speed	Constant output region
Synchronous motors	During sensorless vector control	1:10	1:10	Base speed	Constant output region
	During sensor-equipped vector control NEW	1:1500	1:1500	Base speed	Constant output region

Note) Sensor-equipped control needs to install the PG option card.

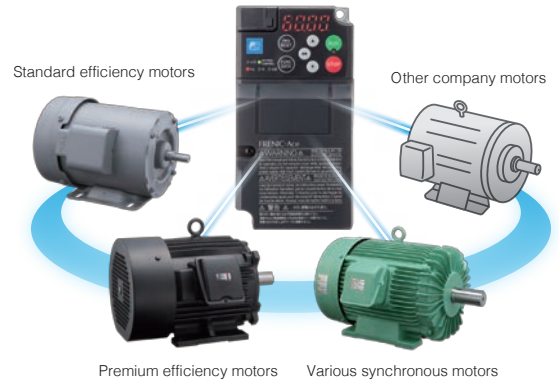

03 Advanced dynamic torque vector control

Enhances our proprietary dynamic torque vector control with new motor constant tuning (that takes into account the voltage of the main circuit) and newly designed magnetic flux observer.

Low-speed frequency 0.5 Hz → starting torque 200%

Example of torque characteristics (typical unit: 22 kW)

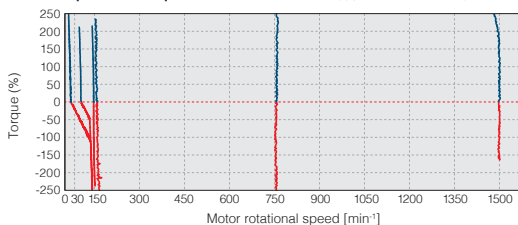

04 Orientation function

Capable of rotor positioning, enabling machinery to be held in place via servo locking after stoppage.

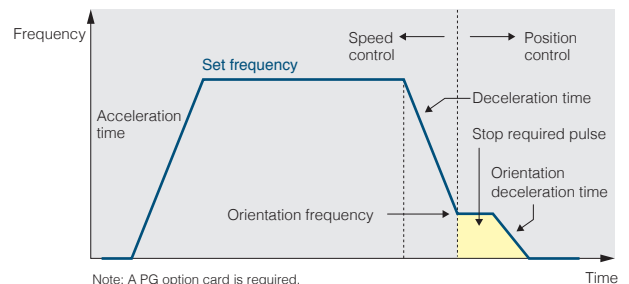

Note: A PG option card is required.

05 Customizable logic functions

Customizable inverter functions to meet your own specific needs. Requires no PLC or external control equipment (relays, timers, etc.) circuits, and can be configured simply by setting and combining various parameters inside the inverter.

Comes with a wide variety of logic symbols and programming steps

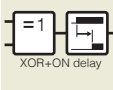
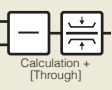
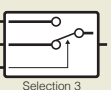
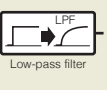
Item	FRENIC-Ace
Logic symbol type (Logical operations, counters, timers, arithmetic operations, comparators, limiters, selectors, holders, etc.)	<p>Total of 138 digital & analog types</p> <div style="display: flex; justify-content: space-around;"> <div style="text-align: center;">  <p>XOR+ON delay T/C 0 T.P 0 Digital operations</p> </div> <div style="text-align: center;">  <p>Calculation + [Through] U.L 0 L.L 0 Analog operations</p> </div> <div style="text-align: center;">  <p>Selection 3 Step 0 Selector</p> </div> <div style="text-align: center;">  <p>LPF Low-pass filter Fil TM. 0 Fix 0 Filter</p> </div> </div>
Number of programming steps	260 steps

* Programming available with FRENIC-Loader4.

Advantages



- High reliability
- Low cost
- Space savings
- Stock savings
- Model integration

06 Enhanced network functions

Expands supported networks, contributing to reduced equipment wiring and data linkage.

Standard

RS-485 port (DX-/DX+) provided separately from the main unit port (RJ-45 connector). Supports two protocols (Modbus RTU and BACnet MS/TP) using these connections.

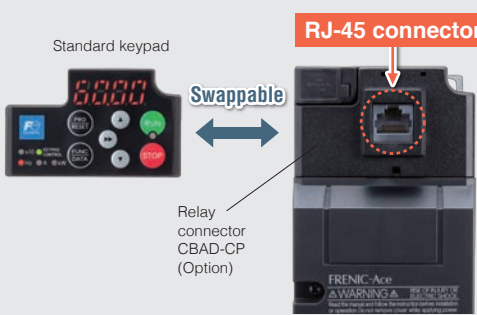

Standard keypad

Swappable

RJ-45 connector

Relay connector CBAD-CP (Option)

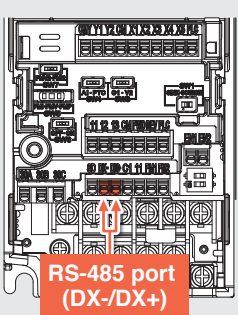

RS-485 port (DX-/DX+)

Standard protocols

- BACnet MS/TP NEW
- Modbus RTU

Option

Option cards are available to connect to various internationally-popular industrial protocols.

Optional protocols

- EtherNet/IP NEW
- PROFINET NEW
- Modbus TCP NEW
- DeviceNet
- PROFIBUS-DP
- CC-Link
- CANopen

07 Side-by-side installation

Enables side-by-side installation and use at full capacity when multiple inverters are arranged in a panel. Saves space via compact control panel design.

E.g., 3-phase 200 V series 0.75 kW



Note) Equivalent to conventional E2 Series.

Note) Install them so that vibration, impact, installation tolerance are taken into consideration. Please note that side-by-side installation can cause problems in removing the adapter for the keypad option.

Extensive lineup

Lineup of 4 types for each power supply voltage.
Supports a wide range of applications from light loads to heavy loads.



01 Wide range of power supply voltages and capacity expansion NEW

Supports wide range of inverter power supply specifications, including 3-phase 200 V series / 400 V series and single-phase 200 V series. Available in capacities up to 22 kW (HHD), a finless type and an Ethernet type have been added to the lineup. Newly added to the lineup were the single-phase, 200 V, high carrier frequency normal duty (HND) type. Delivering a higher current rating for some 400 V series, models in a wide range of capacities are selectable depending on the applications.

Note 1) See the bottom of the page for details.

Capacity [kW] (HHD)		0.1	0.2	0.4	0.75	1.5	2.2	3.7	5.5	7.5	11	15	18.5	22
Basic type [E3S]	3-phase 200 V series	■	■	■	■	■	■	■	■	■	■	■	■	■
	3-phase 400 V series			■	■	■	■	■	■	■	■	■	■	■
	Single-phase 200 V series	■	■	■	■	■								
EMC filter type [E3E] ^{Note 3)}	3-phase 200 V series	■	■	■	■	■	■	■	■	■	■	■	■	■
	3-phase 400 V series			■	■	■	■	■	■	■	■	■	■	■
	Single-phase 200 V series	■	■	■	■	■								
NEW Ethernet type [E3N]	3-phase 200 V series	■	■	■	■	■	■	■	■	■	■	■	■	■
	3-phase 400 V series			■	■	■	■	■	■	■	■	■	■	■
	Single-phase 200 V series	■	■	■	■	■								
NEW Finless type [E3T] ^{Note 2)}	3-phase 200 V series	■	■	■	■	■	■	■	■	■	■	■	■	■
	3-phase 400 V series			■	■	■	■	■	■	■	■	■	■	■
	Single-phase 200 V series	■	■	■	■	■								

Note 3) Three-phase 200 V series differs in specifications. For details, consult our sales representatives.

Ethernet type

» Reduces tact time

Reduces tact time for setting, updating, and monitoring via the Internet.

» Shortens wiring work and reduces wiring

Shortens wiring time and reduces wiring for conventional control signals DI/DO and AI/AO. Compact installation without requiring option cards.

» Compatible with 24 V power supplies

External 24 V power supply input enables checking communication establishment prior to system start-up.

Note) I/O interface is inoperative.



Note) This type does not support the use of option cards.

Finless type

» Space savings

Absence of cooling fins enables more compact and efficient installation of control panels and equipment.

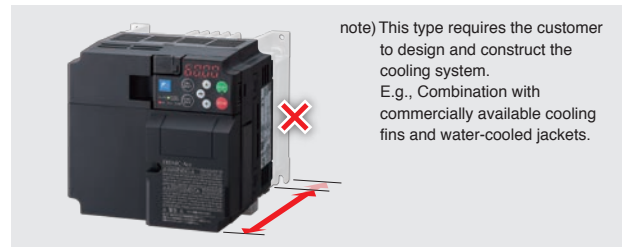

note) This type requires the customer to design and construct the cooling system. E.g., Combination with commercially available cooling fins and water-cooled jackets.

Note 2) For details on the finless type, refer to the FRENIC-Ace Finless type catalog (24A1-E-0185) or consult our sales representatives.

» Depth dimension (D) comparison ^{*Three-phase 200 V series}

Capacity [kW]	Finless type	Basic type
0.1, 0.2	96mm(-2mm)	98mm
0.4	96mm(-17mm)	113mm
0.75	103mm(-42mm)	145mm
1.5 to 3.7	111mm(-45mm)	156mm

Standard applicable motor [kW]	0.4	0.75	1.5	2.2	3.7	5.5	7.5	11	15	18.5	22
FRENIC-Ace(E3)	1.8	3.4	4.8	5.5	9.2	14.8	18	24	31	39	45
FRENIC-Ace(E2)	1.5	2.5	4.2	5.5	9	13	18	24	30	39	45

Note 1) Three-phase 400 V series rated current [A] HHD specification

02 Expansion of functions by replacing control terminal board Option

Available in 3 types of terminal boards as options, enabling application-specific connection and I/O function expansion. Note 1)

RS-485 communication card

Type OPC-CP-RS

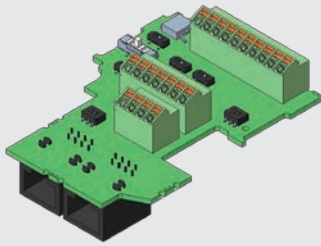

Multidrop connections

Easy connection by replacing the standard terminal board with two RS-485 port connectors (RJ-45).

• Standard terminal block

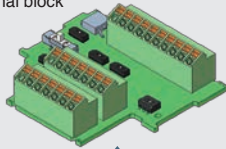

• RS-485 communication card

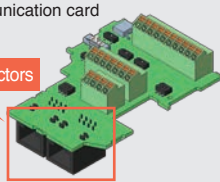

Two RJ-45 connectors

No branch connector required



Easy daisy chain connection without branch connectors or terminal blocks.



PG interface card

Type OPC-CP-PG

5V

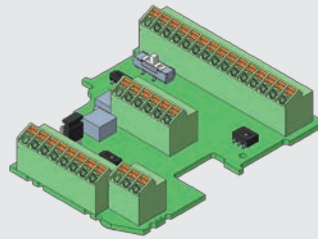

Type OPC-CP-PG3

12V/15V

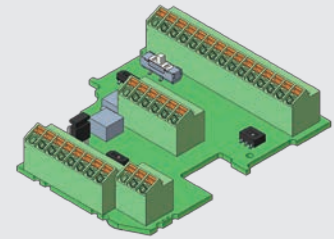

PG signal/pulse signal connection

Supports motor PG signal connection during sensor V/F control and sensor vector control, positioning, and master/follower (synchronous) operation.

• Positioning operation

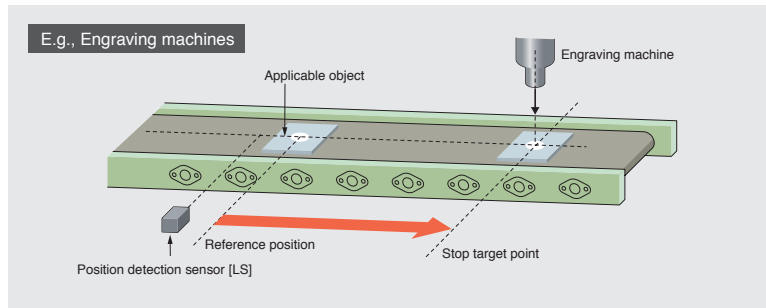

• Master/follower (synchronous) operation

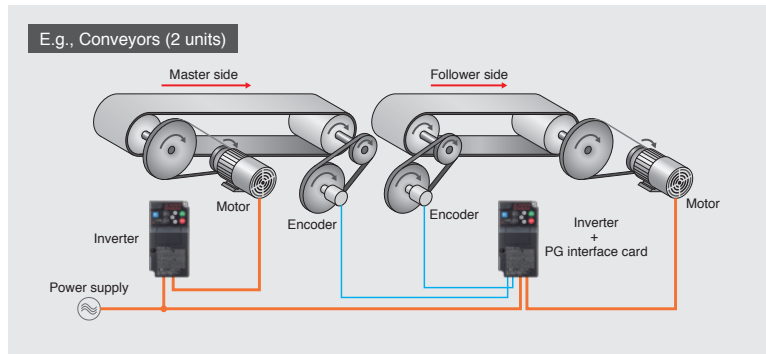

Note 1) For types with built-in Ethernet, the control terminal board cannot be replaced.

Easy maintenance

Easy wiring and setup, as well as remote control, for improved work efficiency. Provides preventive and predictive maintenance functions to ensure safety.

01 Same mounting dimensions

Compatible inverter body mounting dimensions.

*Enables conventional E2 Series replacement and installation.

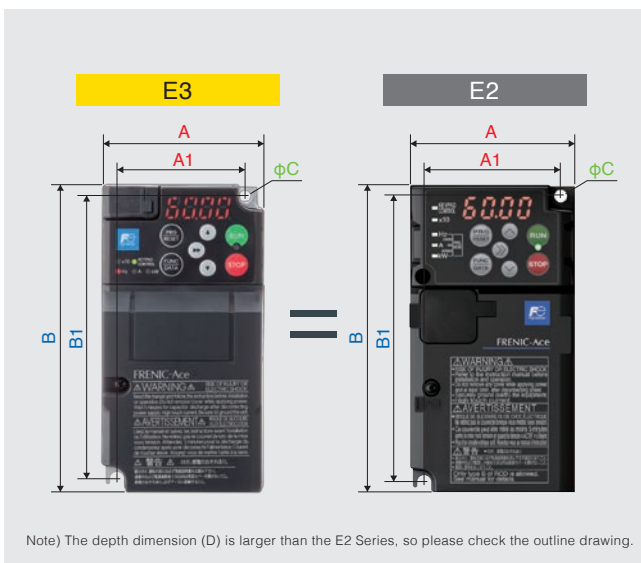

02 Simple wiring

Features a push-in terminal block for the control terminal block to dramatically improve wiring workability.

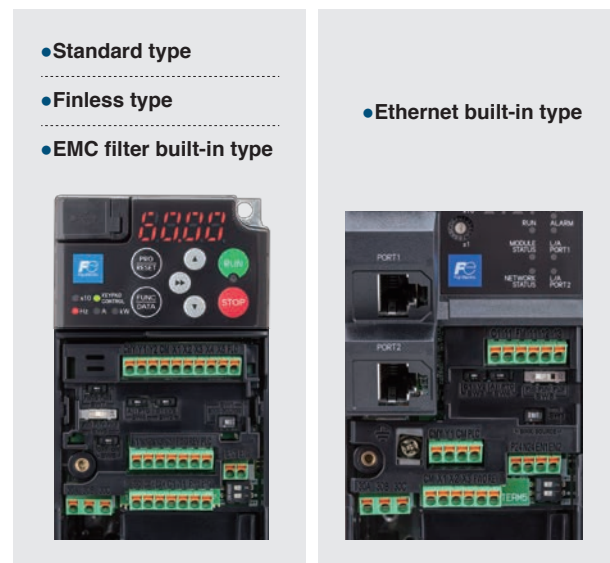

03 Easy parameter migration

Compatibility mode allows parameters read from the previous model to be written directly to the E3 Series.

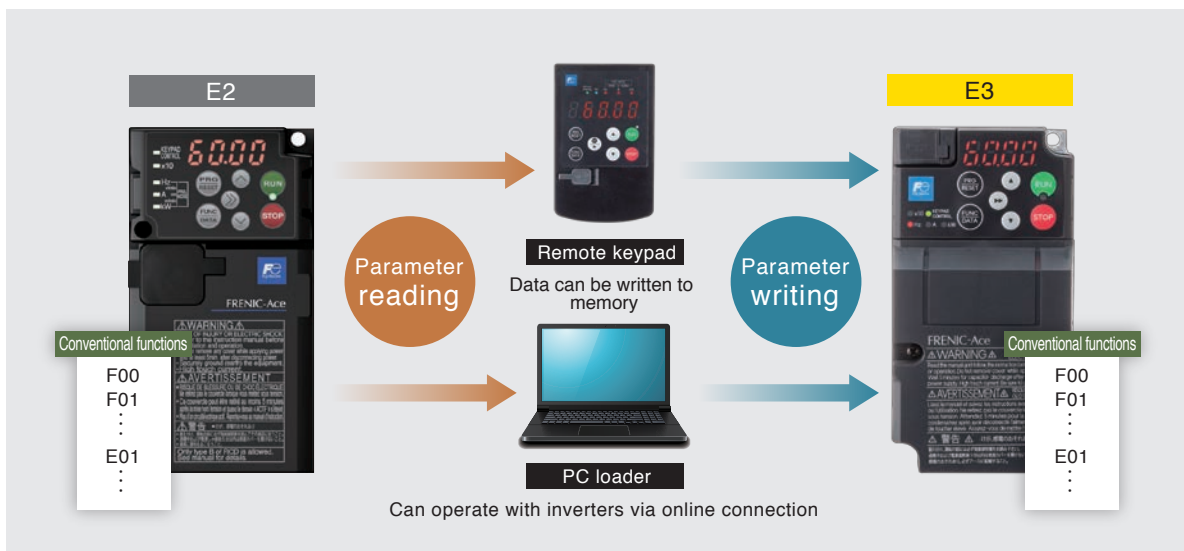

04 Enhanced PC loader functions

Comes standard with a USB port (Mini-B) for direct communication between the inverter and a PC. Parameters can be written to and read from the inverter using only bus power.

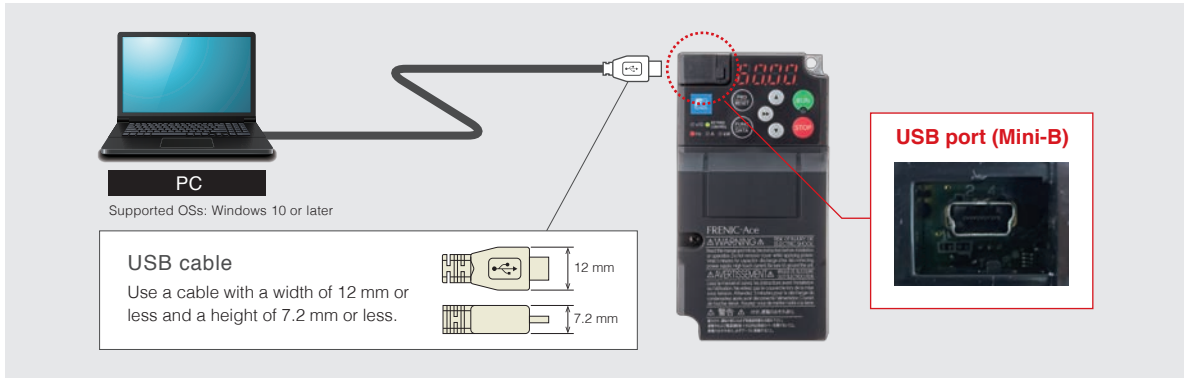

05 Accessible on mobile devices Option

Remote multi-function keypad (optional) enables Bluetooth communication from a smartphone or tablet to read parameters and monitor operating conditions.



06 Enhances alarm history and traceback functions

Alarm history can save and display data for the past 10 alarms.

- Detailed data such as output frequency and output current for the most recent 4 alarms

Number of saves

	No.
No optional keypad	1 * Inverter
Remote keypad (Type: TP-E2)	1 * Keypad
Remote multifunction keypad (Type: TP-A2SW)	100 * SD card

* The numbers above indicate the number of tracebacks.

07 Life expectancy diagnosis and maintenance functions

The keypad and PC loader make it easy to check the status of equipment and detect problems before they occur, helping to reduce production equipment maintenance time and downtime.

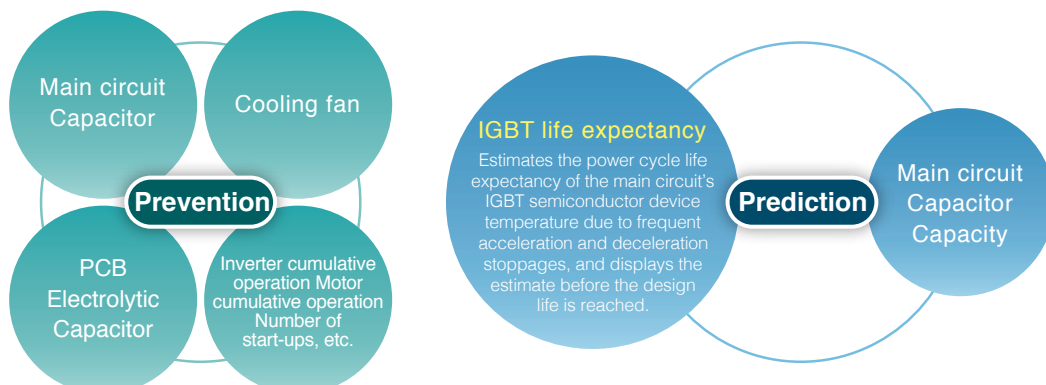

Long life expectancy (main components)

Many of the serviceable parts inside the inverter have been designed to meet customer equipment maintenance cycles.

Life expectancy conditions Ambient temperature 40°C, load factor 100% (HND specification), *However, when the capacity is 3.7 kW or less, the load factor will be 80% *80% (HND specification)

Design life

10

years

Main circuit capacitor



PCB Electrolytic capacitor

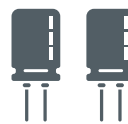

Cooling fan

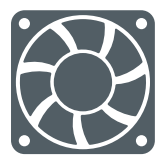

*Excluding finless type

Note 1) The above indicates design life (calculated value) and is not a guarantee value.
 Note 2) The 3-phase 200 V/400 V capacity of 2.2 to 3.7 kW (HND specification) and single-phase 200 V (HND specification) are 7 years.

Other safety and environmental considerations

Includes safety functions

- Compliant with European safety standards.
(EN ISO 13849-1, Cat3/PL:e IEC/EN61800-5-2:2016 SIL3 (STO))
- The inverter comes with a function that enables it to adapt to machine safety. This facilitates the design of main circuit switching devices for ensuring safe stoppages.

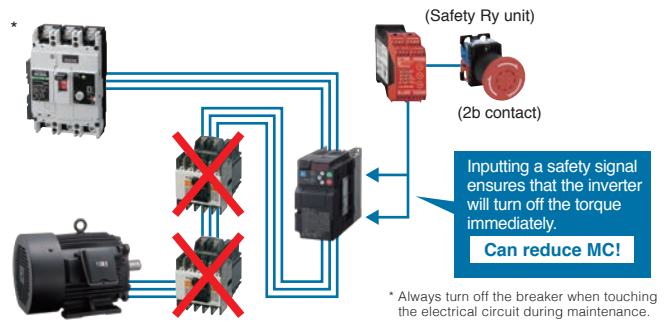

Improves environmental resistance

- Further strengthens PCB coating
IEC60721-3-3/Class 3C2 (Note) Salt-resistant products, etc., can be manufactured to order.

Revised European RoHS Directive



Ten environmental impact substances

- Lead
- Mercury
- Cadmium
- Hexavalent chromium
- Polybrominated biphenyl (PBB)
- Polybrominated diphenyl ether (PBDE)
- Di-2-ethylhexyl phthalate (DEHP)
- Butyl benzyl phthalate (BBP)
- Di-n-butyl phthalate (DBP)
- Diisobutyl phthalate (DIBP)

Globally compliant

Compliant with overseas safety standards.

 European regions England	<p>EC directive</p> <p>CE marking</p> <p>UK UKCA Marking</p> <p>*Great Britain (England, Wales, and Scotland)</p>
 United States Canada	<p>UL standard/cUL standard</p> <p>UL CERTIFIED</p> <p>IND.CONT.EQ. 7B98</p> <p>Finless type (E3T) only</p> <p>E132902 IND.CONT.EQ. 7B98</p>
 Korea	<p>KC certification</p>

Major applications

Widely used in a variety of general and specialized applications.

Conveyors



» Dynamic torque vector control

High starting torque enables smooth transport of large loads and heavy objects.

» Multi-stage frequency driving and analog speed setting

External switches and volume control make it easy to set the driving speed.

» CC-Link communication

CC-Link connectivity is available as an option and can be used in the same networks that support CC-Link-compatible products.

Fans and pumps



» BACNet MS/TP protocol

Supports the BACNet MS/TP protocol used in building automation, providing direct connection to building networks.

» Automatic energy-saving operation

Automatically operates to minimize inverter and motor loss, contributing to equipment energy savings.

» Multi-drive operation

To further improve energy efficiency of machinery and equipment, it enables replacing induction motor-driven systems with synchronous motors without changing inverters.

Compressors



» Sensorless vector control

Drives high-speed motors and synchronous motors up to 599 Hz, contributing to equipment miniaturization and energy savings.

Food processing machines



» High ambient temperatures

Capable of operating at ambient temperatures up to 55°C in high-temperature environments.

Note) Derating is required when using it at 50°C or higher.

» Stable operating speed

» Enables stable operation speeds using slip compensation control.

Features
Main application examples
Model variations
Type number nomenclature
Standard specifications
Common specifications
Terminal specifications
Basic wiring diagram
External dimensions
Keypad
Function codes
Options
Product warranty

Commercial washing machines



» Current limiting

Accelerates while preventing stalling even when laundry is still wet immediately after spinning and draining starts.

» Dynamic torque vector control

Capable of smooth starting at low speeds relative to high starting torque.

» Speed setting

Enables optimum acceleration and deceleration by setting the acceleration and deceleration times.

Press machines



» High-speed responsiveness

Supports the speed sensorless vector of induction motors and ensures constant rotational speed even with load fluctuations, thus stabilizing quality.

» Regeneration avoidance control

Suppresses regenerative energy and ensures continuous operation.

» Built-in braking transistor

Capable of operating in high-load regenerative mode with only a braking resistor.

Hoist cranes



» Customization logic

Enables load-specific automatic double-speed operation by combining a wide variety of digital and analog operation blocks.

» Sensor vector control support

Provides stable lifting and lowering even at low speeds.

» Torque bias control

Supports smooth start-up compensation during lifting and lowering by externally adding load variations to torque commands.

Stacker cranes

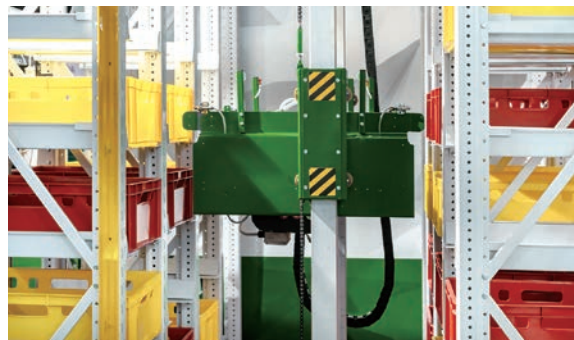

» Brake release signal

Prevents the cargo bed from sliding down or overrunning by using operating condition-based inverter brake signals.

» Predictive maintenance (IGBT life expectancy)

Detects inverter damage in advance by estimating the power cycle life of IGBT element temperatures, thus contributing to shorter system downtimes.

Model Variations

ND (Normal Duty)-mode inverters for general load : 120% for 1 minute

HD (High Duty)-mode inverters for heavy load : 150% for 1 minute

HND (High, Normal Duty)-mode inverters for high carrier frequency, general load : 120% for 1 minute

HHD (High, Heavy Duty)-mode inverters for high carrier frequency, heavy load : 150% for 1 minute, 200% for 0.5 seconds

Model list

Basic type

Standard applicable motor kW (HP)	3-phase 400 V series				3-phase 200 V series		1-phase 200 V series	
	ND	HD	HND	HHD	HND	HHD	HND	HHD NEW
0.1(1/8)						FRN0001E3S-2G		FRN0001E3S-7G
0.2(1/4)					FRN0001E3S-2G	FRN0002E3S-2G	FRN0001E3S-7G	FRN0002E3S-7G
0.4(1/2)				FRN0002E3S-4G	FRN0002E3S-2G	FRN0004E3S-2G	FRN0002E3S-7G	FRN0004E3S-7G
0.55(3/4)							FRN0004E3S-7G	
0.75(1)	FRN0002E3S-4G	FRN0002E3S-4G	FRN0002E3S-4G	FRN0004E3S-4G	FRN0004E3S-2G	FRN0006E3S-2G		FRN0006E3S-7G
1.1(1.5)		FRN0004E3S-4G	FRN0004E3S-4G		FRN0006E3S-2G		FRN0006E3S-7G	
1.5(2)	FRN0004E3S-4G			FRN0006E3S-4G		FRN0010E3S-2G		FRN0010E3S-7G
2.2(3)	FRN0006E3S-4G	FRN0006E3S-4G	FRN0006E3S-4G	FRN0007E3S-4G	FRN0010E3S-2G	FRN0012E3S-2G	FRN0010E3S-7G	FRN0012E3S-7G
3.0(4)	FRN0007E3S-4G	FRN0007E3S-4G	FRN0007E3S-4G		FRN0012E3S-2G		FRN0012E3S-7G	
3.7(5)				FRN0012E3S-4G		FRN0020E3S-2G		
5.5(7.5)	FRN0012E3S-4G	FRN0012E3S-4G	FRN0012E3S-4G	FRN0022E3S-4G	FRN0020E3S-2G	FRN0030E3S-2G		
7.5(10)		FRN0022E3S-4G	FRN0022E3S-4G	FRN0029E3S-4G	FRN0030E3S-2G	FRN0040E3S-2G		
11(15)	FRN0022E3S-4G	FRN0029E3S-4G	FRN0029E3S-4G	FRN0037E3S-4G	FRN0040E3S-2G	FRN0056E3S-2G		
15(20)	FRN0029E3S-4G	FRN0037E3S-4G	FRN0037E3S-4G	FRN0044E3S-4G	FRN0056E3S-2G	FRN0069E3S-2G		
18.5(25)	FRN0037E3S-4G	FRN0044E3S-4G	FRN0044E3S-4G	FRN0059E3S-4G	FRN0069E3S-2G	FRN0088E3S-2G		
22(30)	FRN0044E3S-4G	FRN0059E3S-4G	FRN0059E3S-4G	FRN0072E3S-4G	FRN0088E3S-2G	FRN0115E3S-2G		
30(40)	FRN0059E3S-4G	FRN0072E3S-4G	FRN0072E3S-4G		FRN0115E3S-2G			
37(50)	FRN0072E3S-4G							

EMC filter built-in type Note

Standard applicable motor kW (HP)	3-phase 400 V series				1-phase 200 V series
	ND	HD	HND	HHD	HHD
0.1(1/8)					FRN0001E3E-7G
0.2(1/4)					FRN0002E3E-7G
0.4(1/2)				FRN0002E3E-4G	FRN0004E3E-7G
0.75(1)	FRN0002E3E-4G	FRN0002E3E-4G	FRN0002E3E-4G	FRN0004E3E-4G	FRN0006E3E-7G
1.1(1.5)		FRN0004E3E-4G	FRN0004E3E-4G		
1.5(2)	FRN0004E3E-4G			FRN0006E3E-4G	FRN0010E3E-7G
2.2(3)	FRN0006E3E-4G	FRN0006E3E-4G	FRN0006E3E-4G	FRN0007E3E-4G	FRN0012E3E-7G
3.0(4)	FRN0007E3E-4G	FRN0007E3E-4G	FRN0007E3E-4G		
3.7(5)				FRN0012E3E-4G	
5.5(7.5)	FRN0012E3E-4G	FRN0012E3E-4G	FRN0012E3E-4G	FRN0022E3E-4G	
7.5(10)		FRN0022E3E-4G	FRN0022E3E-4G	FRN0029E3E-4G	
11(15)	FRN0022E3E-4G	FRN0029E3E-4G	FRN0029E3E-4G	FRN0037E3E-4G	
15(20)	FRN0029E3E-4G	FRN0037E3E-4G	FRN0037E3E-4G	FRN0044E3E-4G	
18.5(25)	FRN0037E3E-4G	FRN0044E3E-4G	FRN0044E3E-4G	FRN0059E3E-4G	
22(30)	FRN0044E3E-4G	FRN0059E3E-4G	FRN0059E3E-4G	FRN0072E3E-4G	
30(40)	FRN0059E3E-4G	FRN0072E3E-4G	FRN0072E3E-4G		
37(50)	FRN0072E3E-4G				

NEW Ethernet built-in type

Standard applicable motor kW (HP)	3-phase 400 V series				3-phase 200 V series		1-phase 200 V series	
	ND	HD	HND	HHD	HND	HHD	HND	HHD
0.1(1/8)						FRN0001E3N-2G		FRN0001E3N-7G
0.2(1/4)					FRN0001E3N-2G	FRN0002E3N-2G	FRN0001E3N-7G	FRN0002E3N-7G
0.4(1/2)				FRN0002E3N-4G	FRN0002E3N-2G	FRN0004E3N-2G	FRN0002E3N-7G	FRN0004E3N-7G
0.55(3/4)							FRN0004E3N-7G	
0.75(1)	FRN0002E3N-4G	FRN0002E3N-4G	FRN0002E3N-4G	FRN0004E3N-4G	FRN0004E3N-2G	FRN0006E3N-2G		FRN0006E3N-7G
1.1(1.5)		FRN0004E3N-4G	FRN0004E3N-4G		FRN0006E3N-2G		FRN0006E3N-7G	
1.5(2)	FRN0004E3N-4G			FRN0006E3N-4G		FRN0010E3N-2G		FRN0010E3N-7G
2.2(3)	FRN0006E3N-4G	FRN0006E3N-4G	FRN0006E3N-4G	FRN0007E3N-4G	FRN0010E3N-2G	FRN0012E3N-2G	FRN0010E3N-7G	FRN0012E3N-7G
3.0(4)	FRN0007E3N-4G	FRN0007E3N-4G	FRN0007E3N-4G		FRN0012E3N-2G		FRN0012E3N-7G	
3.7(5)				FRN0012E3N-4G		FRN0020E3N-2G		
5.5(7.5)	FRN0012E3N-4G	FRN0012E3N-4G	FRN0012E3N-4G	FRN0022E3N-4G	FRN0020E3N-2G	FRN0030E3N-2G		
7.5(10)		FRN0022E3N-4G	FRN0022E3N-4G	FRN0029E3N-4G	FRN0030E3N-2G	FRN0040E3N-2G		
11(15)	FRN0022E3N-4G	FRN0029E3N-4G	FRN0029E3N-4G	FRN0037E3N-4G	FRN0040E3N-2G	FRN0056E3N-2G		
15(20)	FRN0029E3N-4G	FRN0037E3N-4G	FRN0037E3N-4G	FRN0044E3N-4G	FRN0056E3N-2G	FRN0069E3N-2G		
18.5(25)	FRN0037E3N-4G	FRN0044E3N-4G	FRN0044E3N-4G	FRN0059E3N-4G	FRN0069E3N-2G	FRN0088E3N-2G		
22(30)	FRN0044E3N-4G	FRN0059E3N-4G	FRN0059E3N-4G	FRN0072E3N-4G	FRN0088E3N-2G	FRN0115E3N-2G		
30(40)	FRN0059E3N-4G	FRN0072E3N-4G	FRN0072E3N-4G		FRN0115E3N-2G			
37(50)	FRN0072E3N-4G							

Note) Three-phase 200 V series differs in specifications. For details, consult our sales representatives.

How to read the inverter modelerter model

FRN 0001 E 3 S - 2 G

Code	Series name
FRN	FRENIC series

Three-phase 200V series

Code	Applicable motor rating			
	HHD	HND	HD	ND
0001	0.1	0.2	-	-
0002	0.2	0.4	-	-
0004	0.4	0.75	-	-
0006	0.75	1.1	-	-
0010	1.5	2.2	-	-
0012	2.2	3.0	-	-
0020	3.7	5.5	-	-
0030	5.5	7.5	-	-
0040	7.5	11	-	-
0056	11	15	-	-
0069	15	18.5	-	-
0088	18.5	22	-	-
0115	22	30	-	-

Three-phase 400V series

Code	Applicable motor rating			
	HHD	HND	HD	ND
0002	0.4	0.75	0.75	0.75
0004	0.75	1.1	1.1	1.5
0006	1.5	2.2	2.2	2.2
0007	2.2	3	3	3
0012	3.7	5.5	5.5	5.5
0022	5.5	7.5	7.5	11
0029	7.5	11	11	15
0037	11	15	15	18.5
0044	15	18.5	18.5	22
0059	18.5	22	22	30
0072	22	30	30	37

Single-phase 200V series

Code	Applicable motor rating			
	HHD	HND	HD	ND
0001	0.1	0.2	-	-
0002	0.2	0.4	-	-
0004	0.4	0.55	-	-
0006	0.75	1.1	-	-
0010	1.5	2.2	-	-
0012	2.2	3.0	-	-

Single-phase 200V series (EMC filter build-in type)

Code	Applicable motor rating [kW]			
	HHD	HND	HD	ND
0001	0.1	-	-	-
0002	0.2	-	-	-
0003	0.4	-	-	-
0005	0.75	-	-	-
0008	1.5	-	-	-
0011	2.2	-	-	-

Code	Destination / Manual
G	Global / English

Code	Power supply
2	Three-phase 200V
4	Three-phase 400V
7	Single-phase 200V

Code	Enclosure
S	Standard (Basic type)
E	EMC filter built-in type
N	Ethernet built-in type

Code	Development code
3	3

Code	Applicable area
E	For industrial / High performance / Multiple functionality

Features

Main application examples

Model variations

Type number nomenclature

Standard specifications

Common specifications

Terminal specifications

Basic wiring diagram

External dimensions

Keypad

Function codes

Options

Product warranty

Standard specifications

Three-phase 200V

Basic type

Item			Specification														
Type(FRN□□□□E3S-2G)			0001	0002	0004	0006	0010	0012 *g	0020 *g	0030	0040	0056	0069	0088	0115		
Standard applicable motor *1	HHD	kW	0.1	0.2	0.4	0.75	1.5	2.2	3.7	5.5	7.5	11	15	18.5	22		
		HP	1/8	1/4	1/2	1	2	3	5	7.5	10	15	20	25	30		
	HND	kW	0.2	0.4	0.75	1.1	2.2	3	5.5	7.5	11	15	18.5	22	30		
		HP	1/4	1/2	1	1.5	3	4	7.5	10	15	20	25	30	40		
Output ratings	Rated capacity [kVA] *2		HHD	0.4	0.6	1.1	1.9	3	4.2	6.7	9.5	13	18	23	29	34	
			HND	0.5	0.8	1.3	2.3	3.7	4.6	7.5	11	15	21	26	34	44	
	Rated voltage [V] *3		Three-phase 200 to 240 V (with AVR function)														
	Rated current [A] *4		HHD	1	1.6	3	5	8	11	17.5	25	33	47	60	76	90	
			HND	1.3	2	3.5	6	9.6	12	19.6	30	40	56	69	88	115	
	Overload current rating [A] (permissible overload time)		HHD	150% for 1 minute, 200% for 0.5 seconds													
			HND	120% for 1 minute													
	Ambient temperature		HHD	-10 to +55 °C [14 to 131 °F] (current derating necessary in +50 to +55 °C [122 to 131 °F] range)													
			HND	-10 to +55 °C [14 to 131 °F] (current derating necessary in +50 to +55 °C [122 to 131 °F] range) Type of 0012 to 0020 -10 to +50 °C [14 to 122 °F] (current derating necessary in +40 to +50 °C [104 to 122 °F] range)													
	Rated frequency [Hz]		50 / 60 Hz														
Voltage, frequency		Three-phase 200 to 240 V, 50/60 Hz															
Voltage, frequency fluctuation		Voltage: +10 to -15% (interphase unbalance ratio: 2% or less) *8, Frequency: +5 to -5 %															
Input ratings	Rated current [A] *5	With DCR	HHD	0.57	0.93	1.6	3	5.7	8.3	14	21.1	28.8	42.2	57.6	71	84.4	
			HND	0.93	1.6	3	4.3	8.3	11.7	19.9	28.8	42.2	57.6	71	84.4	114	
		Without DCR	HHD	1.1	1.8	3.1	5.3	9.5	13.2	22.2	31.5	42.7	60.7	80.1	97	112	
			HND	1.8	2.6	4.9	6.7	12.8	17.9	28.5	42.7	60.7	80.1	97	112	151	
	Required power supply capacity (with DCR) [kVA] *6		HHD	0.2	0.4	0.6	1.1	2	2.9	4.9	7.3	10	15	20	25	30	
			HND	0.4	0.6	1.1	1.5	2.9	4.1	6.9	10	15	20	25	30	40	
Auxiliary control power supply voltage		-													Single-phase 200 to 240 V, 50/60 Hz		
Braking	Torque *7		HHD	150%			100%		70%		40%			20%			
			HND	75%		53%	68%	48%	29%	27%	15%						
	Braking transistor		Built-in														
	Connectable resistance value [Ω]		100 to 120				40 to 120			33 to 120	20 min.	15 min.	10 min.	8.6 min.	4 min.		
Braking resistor [Ω]		Option															
DC reactor (DCR)		Option															
Protective construction (IEC 60529)		IP20 enclosed type, UL open type															
Cooling system		Natural cooling						Fan cooling									
Weight [kg(lbs)]		0.5 (1.1)	0.5 (1.1)	0.6 (1.3)	0.8 (1.8)	1.4 (3.1)	1.4 (3.1)	1.7 (3.7)	3.8 (8.4)	4 (8.8)	5.3 (12)	5.4 (12)	11 (24)	12 (26)			

(*1) Standard applicable motor indicates Fuji Electric 4-pole standard motors. Select a motor not only based on inverter output (kW), but also so that the output rated current is greater than the motor rated current.

(*2) The rated capacity indicates 220 V for the 200V series, and 440 V for the 400V series.

(*3) It is not possible to output a voltage higher than the power supply voltage.

(*4) Setting the carrier frequency (F26) to the following value or above requires current derating.

HHD spec. of types FRN0001E3□-2G to FRN0020E3□-2G : 8 kHz, FRN0030E3□-2G to FRN0115E3□-2G; 10 kHz

HND spec. of types FRN0001E3□-2G to FRN0020E3□-2G : 4 kHz, FRN0030E3□-2G to FRN0088E3□-2G; 10 kHz,

FRN0115E3□-2G; 6 kHz

(*5) This indicates the estimated value if the power supply capacity is 500 kVA (10 times inverter capacity if inverter capacity exceeds 50 kVA), and the motor is connected to a power supply of %X = 5%.

(*6) This indicates the capacity when the motor is equipped with a DC reactor (DCR).

(*7) This is the average braking torque when performing individual operation. (This will vary based on the motor efficiency.)

(*8) Interphase unbalance ratio [%] = (Max. voltage [V] - min. voltage [V])/Three-phase average voltage [V] x 67 (see IEC/EN 61800-3). If using the motor with an unbalance ratio of 2 to 3%, use an AC reactor (ACR: option).

(*9) For FRN0012/0020E3S-2G, FRN0012/0020E3N-2G HND specifications, If the ambient temperature is 40°C or higher, the output current must be derated by 1%/°C.

Three-phase 200V

Ethernet built-in type

Item			Specification													
Type(FRN□□□□E3N-2G)			0001	0002	0004	0006	0010	0012* ₉	0020* ₉	0030	0040	0056	0069	0088	0115	
Standard applicable motor *1	HHD	kW	0.1	0.2	0.4	0.75	1.5	2.2	3.7	5.5	7.5	11	15	18.5	22	
		HP	1/8	1/4	1/2	1	2	3	5	7.5	10	15	20	25	30	
	HND	kW	0.2	0.4	0.75	1.1	2.2	3	5.5	7.5	11	15	18.5	22	30	
		HP	1/4	1/2	1	1.5	3	4	7.5	10	15	20	25	30	40	
Output ratings	Rated capacity [kVA] *2		HHD	0.4	0.6	1.1	1.9	3	4.2	6.7	9.5	13	18	23	29	34
			HND	0.5	0.8	1.3	2.3	3.7	4.6	7.5	11	15	21	26	34	44
	Rated voltage [V] *3		Three-phase 200 to 240 V (with AVR function)													
	Rated current [A] *4		HHD	1	1.6	3	5	8	11	17.5	25	33	47	60	76	90
			HND	1.3	2	3.5	6	9.6	12	19.6	30	40	56	69	88	115
	Overload current rating [A] (permissible overload time)		HHD	150% for 1 minute, 200% for 0.5 seconds												
			HND	120% for 1 minute												
	Ambient temperature		HHD	-10 to +55 °C [14 to 131 °F] (current derating necessary in +50 to +55 °C [122 to 131 °F] range)												
			HND	-10 to +55 °C [14 to 131 °F] (current derating necessary in +50 to +55 °C [122 to 131 °F] range) Type of 0012 to 0020 -10 to +50 °C [14 to 122 °F] (current derating necessary in +40 to +50 °C [104 to 122 °F] range)												
	Rated frequency [Hz]		50 / 60 Hz													
Input ratings	Voltage, frequency		Three-phase 200 to 240 V, 50/60 Hz													
	Voltage, frequency fluctuation		Voltage: +10 to -15% (interphase unbalance ratio: 2% or less) *8, Frequency: +5 to -5 %													
	Rated current [A] *5	With DCR	HHD	0.57	0.93	1.6	3	5.7	8.3	14	21.1	28.8	42.2	57.6	71	84.4
			HND	0.93	1.6	3	4.3	8.3	11.7	19.9	28.8	42.2	57.6	71	84.4	114
		Without DCR	HHD	1.1	1.8	3.1	5.3	9.5	13.2	22.2	31.5	42.7	60.7	80.1	97	112
			HND	1.8	2.6	4.9	6.7	12.8	17.9	28.5	42.7	60.7	80.1	97	112	151
	Required power supply capacity (with DCR) [kVA] *6		HHD	0.2	0.4	0.6	1.1	2	2.9	4.9	7.3	10	15	20	25	30
		HND	0.4	0.6	1.1	1.5	2.9	4.1	6.9	10	15	20	25	30	40	
Auxiliary control power supply voltage		-												Single-phase 200 to 240 V, 50/60 Hz		
Braking	Torque *7		HHD	150%			100%		70%	40%		20%				
			HND	75%		53%	68%	48%	29%	27%	15%					
	Braking transistor		Built-in													
	Connectable resistance value [Ω]		100 to 120				40 to 120			33 to 120	20 min.	15 min.	10 min.	8.6 min.	4 min.	
Braking resistor [Ω]		Option														
DC reactor (DCR)		Option														
Protective construction (IEC 60529)		IP20 enclosed type, UL open type														
Cooling system		Natural cooling						Fan cooling								
Weight [kg(lbs)]		0.5 (1.1)	0.5 (1.1)	0.7 (1.5)	0.9 (2.0)	1.4 (3.1)	1.4 (3.1)	1.7 (3.7)	3.8 (8.4)	4 (8.8)	5.3 (12)	5.4 (12)	11 (24)	12 (26)		

(*1) Standard applicable motor indicates Fuji Electric 4-pole standard motors. Select a motor not only based on inverter output (kW), but also so that the output rated current is greater than the motor rated current.

(*2) The rated capacity indicates 220 V for the 200V series, and 440 V for the 400V series.

(*3) It is not possible to output a voltage higher than the power supply voltage.

(*4) Setting the carrier frequency (F26) to the following value or above requires current derating.

HHD spec. of types FRN0001E3□-2G to FRN0020E3□-2G : 8 kHz, FRN0030E3□-2G to FRN0115E3□-2G; 10 kHz

HND spec. of types FRN0001E3□-2G to FRN0020E3□-2G : 4 kHz, FRN0030E3□-2G to FRN0088E3□-2G; 10 kHz,

FRN0115E3□-2G; 6 kHz

(*5) This indicates the estimated value if the power supply capacity is 500 kVA (10 times inverter capacity if inverter capacity exceeds 50 kVA), and the motor is connected to a power supply of %X = 5%.

(*6) This indicates the capacity when the motor is equipped with a DC reactor (DCR).

(*7) This is the average braking torque when performing individual operation. (This will vary based on the motor efficiency.)

(*8) Interphase unbalance ratio [%] = (Max. voltage [V] - min. voltage [V]) / Three-phase average voltage [V] x 67 (see IEC/EN 61800-3). If using the motor with an unbalance ratio of 2 to 3%, use an AC reactor (ACR: option).

(*9) For FRN0012/0020E3S-2G, FRN0012/0020E3N-2G HND specifications, If the ambient temperature is 40°C or higher, the output current must be derated by 1%/°C.

Standard specifications

Three-phase 400V

Basic type

Item		Specification													
Type(FRN□□□□E3S-4G)		0002	0004	0006	0007 *g	0012 *g	0022	0029	0037	0044	0059	0072			
Standard applicable motor *1	HHD	kW	0.4	0.75	1.5	2.2	3.7	5.5	7.5	11	15	18.5	22		
		HP	1/2	1	2	3	5	7.5	10	15	20	25	30		
	HND	kW	0.75	1.1	2.2	3	5.5	7.5	11	15	18.5	22	30		
		HP	1	1.5	3	4	7.5	10	15	20	25	30	40		
	HD	kW	0.75	1.1	2.2	3	5.5	7.5	11	15	18.5	22	30		
		HP	1	1.5	3	4	7.5	10	15	20	25	30	40		
	ND	kW	0.75	1.5	2.2	3	5.5	11	15	18.5	22	30	37		
		HP	1	2	3	4	7.5	15	20	25	30	40	50		
Output ratings	Rated capacity [kVA] *2		HHD	1.1	1.9	3.2	4.2	7.0	11	14	18	24	30	34	
			HND	1.4	2.6	3.8	4.8	8.5	13	18	27	31	34	46	
			HD	1.4	2.6	3.8	4.8	8.5	13	18	24	29	34	46	
			ND	1.6	3.1	4.2	5.3	9.1	16	22	28	34	45	55	
	Rated voltage [V] *3		Three-phase 400 to 480 V (with AVR function)												
	Rated current [A] *4		HHD	1.5	2.5	4.2	5.5	9.2	14.8	18	24	31	39	45	
			HND	1.8	3.4	5	6.3	11.1	17.5	23	35	41	45	60	
			HD	1.8	3.4	5	6.3	11.1	17.5	23	35	41	45	60	
			ND	2.1	4.1	5.5	6.9	12	21.5	28.5	37	44	59	72	
	Overload current rating [A] (permissible overload time)		HHD	150% for 1 minute, 200% for 0.5 seconds											
			HND	120% for 1 minute											
			HD	150% for 1 minute											
ND			120% for 1 minute												
Ambient temperature		HHD	-10 to +55 °C [14 to 131 °F] (current derating necessary in +50 to +55 °C [122 to 131 °F] range)												
		HND	-10 to +55 °C [14 to 131 °F] (current derating necessary in +50 to +55 °C [122 to 131 °F] range) Type of 0007 to 0012 -10 to +50 °C [14 to 122 °F] (current derating necessary in +40 to +50 °C [104 to 122 °F] range)												
		HD	-10 to +50 °C [14 to 122 °F] (current derating necessary in +40 to +50 °C [104 to 122 °F] range)												
		ND	-10 to +50 °C [14 to 122 °F] (current derating necessary in +40 to +50 °C [104 to 122 °F] range)												
Rated frequency [Hz]		50 / 60 Hz													
Voltage, frequency		Three-phase 380 to 480 V, 50/60 Hz													
Voltage, frequency fluctuation		Voltage: +10 to -15% (interphase unbalance ratio: 2% or less) *8, Frequency: +5 to -5%													
Input ratings	Rated current [A] *5		With DCR	HHD	0.85	1.6	3	4.4	7.3	10.6	14.4	21.1	28.8	35.5	42.2
				HND	1.5	2.1	4.2	5.8	10.1	14.4	21.1	28.8	35.5	42.2	57
				HD	1.5	2.1	4.2	5.8	10.1	14.4	21.1	28.8	35.5	42.2	57
				ND	1.5	2.9	4.2	5.8	10.1	21.1	28.8	35.5	42.2	57	68.5
			Without DCR	HHD	1.7	3.1	5.9	8.2	13	17.3	23.2	33	43.8	52.3	60.6
				HND	2.7	3.9	7.3	11.3	16.8	23.2	33	43.8	52.3	60.6	77.9
				HD	2.7	3.9	7.3	11.3	16.8	23.2	33	43.8	52.3	60.6	77.9
				ND	2.7	4.8	7.3	11.3	16.8	33	43.8	52.3	60.6	77.9	94.3
	Required power supply capacity (with DCR) [kVA] *6		HHD	0.6	1.2	2.1	3.1	5.1	7.3	10	15	20	25	29	
			HND	1.1	1.5	3	4.1	7	10	15	20	25	29	39	
HD			1.1	1.5	3	4.1	7	10	15	20	25	29	39		
ND			1.1	2.1	3	4.1	7	15	20	25	29	39	47		
Auxiliary control power supply voltage		-										Single-phase 380 to 480 V, 50/60 Hz			
Braking	Torque *7		HHD	100%			70%			40%			20%		
			HND	53%	68%	48%	29%	27%	15%						
			HD	53%	68%	48%	29%	27%	15%						
			ND	53%	50%	48%	29%	27%	12%						
	Braking transistor		Built-in												
Connectable resistance value [Ω]		200			160 to 200			130 to 200	80min.	60min.	40min.	34.4min.	16min.		
Braking resistor [Ω]		Option													
DC reactor (DCR)		Option													
Protective construction (IEC 60529)		IP20 enclosed type, UL open type													
Cooling system		Natural cooling					Fan cooling								
Weight [kg](lbs)]		1.1	1.4	1.4	1.4	1.7	3.8	3.8	5.2	5.4	11	11			
		[2.4]	[3.1]	[3.1]	[3.1]	[3.7]	[8.4]	[8.4]	[11]	[12]	[24]	[24]			

(*1) Standard applicable motor indicates Fuji Electric 4-pole standard motors. Select a motor not only based on inverter output (kW), but also so that the output rated current is greater than the motor rated current.

(*2) The rated capacity indicates 220 V for the 200V series, and 440 V for the 400V series.

(*3) It is not possible to output a voltage higher than the power supply voltage.

(*4) Setting the carrier frequency (F26) to the following value or above requires current derating.

HHD spec. of types FRN0002E3□-4G to FRN0012E3□-4G ; 8 kHz, FRN0022E3□-4G to FRN0072E3□-4G; 10 kHz

HND spec. of types FRN0002E3□-4G to FRN0012E3□-4G ; 8 kHz, FRN0022E3□-4G to FRN0059E3□-4G; 10 kHz, FRN0072E3□-4G; 6 kHz

HD / ND spec. of types FRN0002E3□-4G to FRN0072E3□-4G; 4 kHz

(*5) This indicates the estimated value if the power supply capacity is 500 kVA (10 times inverter capacity if inverter capacity exceeds 50 kVA), and the motor is connected to a power supply of %X = 5%. (*6) This indicates the capacity when the motor is equipped with a DC reactor (DCR).

(*7) This is the average braking torque when performing individual operation. (This will vary based on the motor efficiency.)

(*8) Interphase unbalance ratio [%] = (Max. voltage [V] - min. voltage [V])/Three-phase average voltage [V] x 67 (see IEC/EN 61800-3). If using the motor with an unbalance ratio of 2 to 3%, use an AC reactor (ACR: option).

(*9) For FRN0007/0012E3S-4G, FRN0007/0012E3N-4G HND specifications, If the ambient temperature is 40°C or higher, the output current must be derated by 1%/°C.

Three-phase 400V

Ethernet built-in type

Item		Specification													
Type(FRN□□□□E3N-4G)		0002	0004	0006	0007 *9	0012 *9	0022	0029	0037	0044	0059	0072			
Standard applicable motor *1	HHD	kW	0.4	0.75	1.5	2.2	3.7	5.5	7.5	11	15	18.5	22		
		HP	1/2	1	2	3	5	7.5	10	15	20	25	30		
	HND	kW	0.75	1.1	2.2	3	5.5	7.5	11	15	18.5	22	30		
		HP	1	1.5	3	4	7.5	10	15	20	25	30	40		
	HD	kW	0.75	1.1	2.2	3	5.5	7.5	11	15	18.5	22	30		
		HP	1	1.5	3	4	7.5	10	15	20	25	30	40		
	ND	kW	0.75	1.5	2.2	3	5.5	11	15	18.5	22	30	37		
		HP	1	2	3	4	7.5	15	20	25	30	40	50		
Output ratings	Rated capacity [kVA] *2		HHD	1.1	1.9	3.2	4.2	7.0	11	14	18	24	30	34	
			HND	1.4	2.6	3.8	4.8	8.5	13	18	27	31	34	46	
			HD	1.4	2.6	3.8	4.8	8.5	13	18	24	29	34	46	
			ND	1.6	3.1	4.2	5.3	9.1	16	22	28	34	45	55	
	Rated voltage [V] *3		Three-phase 400 to 480 V (with AVR function)												
	Rated current [A] *4		HHD	1.5	2.5	4.2	5.5	9.2	14.8	18	24	31	39	45	
			HND	1.8	3.4	5	6.3	11.1	17.5	23	35	41	45	60	
			HD	1.8	3.4	5	6.3	11.1	17.5	23	35	41	45	60	
			ND	2.1	4.1	5.5	6.9	12	21.5	28.5	37	44	59	72	
	Overload current rating [A] (permissible overload time)		HHD	150% for 1 minute, 200% for 0.5 seconds											
			HND	120% for 1 minute											
			HD	150% for 1 minute											
ND			120% for 1 minute												
Ambient temperature		HHD	-10 to +55 °C [14 to 131 °F] (current derating necessary in +50 to +55 °C [122 to 131 °F] range)												
		HND	-10 to +55 °C [14 to 131 °F] (current derating necessary in +50 to +55 °C [122 to 131 °F] range) Type of 0007 to 0012 -10 to +50 °C [14 to 122 °F] (current derating necessary in +40 to +50 °C [104 to 122 °F] range)												
		HD	-10 to +50 °C [14 to 122 °F] (current derating necessary in +40 to +50 °C [104 to 122 °F] range)												
		ND	-10 to +50 °C [14 to 122 °F] (current derating necessary in +40 to +50 °C [104 to 122 °F] range)												
Rated frequency [Hz]		50 / 60 Hz													
Voltage, frequency		Three-phase 380 to 480 V, 50/60 Hz													
Voltage, frequency fluctuation		Voltage: +10 to -15% (interphase unbalance ratio: 2% or less) *8, Frequency: +5 to -5 %													
Input ratings	Rated current [A] *5		With DCR	HHD	0.85	1.6	3	4.4	7.3	10.6	14.4	21.1	28.8	35.5	42.2
				HND	1.5	2.1	4.2	5.8	10.1	14.4	21.1	28.8	35.5	42.2	57
				HD	1.5	2.1	4.2	5.8	10.1	14.4	21.1	28.8	35.5	42.2	57
				ND	1.5	2.9	4.2	5.8	10.1	21.1	28.8	35.5	42.2	57	68.5
			Without DCR	HHD	1.7	3.1	5.9	8.2	13	17.3	23.2	33	43.8	52.3	60.6
				HND	2.7	3.9	7.3	11.3	16.8	23.2	33	43.8	52.3	60.6	77.9
				HD	2.7	3.9	7.3	11.3	16.8	23.2	33	43.8	52.3	60.6	77.9
				ND	2.7	4.8	7.3	11.3	16.8	33	43.8	52.3	60.6	77.9	94.3
	Required power supply capacity (with DCR) [kVA] *6		HHD	0.6	1.2	2.1	3.1	5.1	7.3	10	15	20	25	29	
			HND	1.1	1.5	3	4.1	7	10	15	20	25	29	39	
			HD	1.1	1.5	3	4.1	7	10	15	20	25	29	39	
			ND	1.1	2.1	3	4.1	7	15	20	25	29	39	47	
Auxiliary control power supply voltage		-										Single-phase 380 to 480 V, 50/60 Hz			
Braking	Torque *7		HHD	100%		70%		40%		20%					
			HND	53%	68%	48%	29%	27%	15%						
			HD	53%	68%	48%	29%	27%	15%						
			ND	53%	50%	48%	29%	27%	12%						
			Braking transistor		Built-in										
Connectable resistance value [Ω]		200		160 to 200		130 to 200		80min.	60min.	40min.	34.4min.	16min.			
Braking resistor [Ω]		Option													
DC reactor (DCR)		Option													
Protective construction (IEC 60529)		IP20 enclosed type, UL open type													
Cooling system		Natural cooling					Fan cooling								
Weight [kg(lbs)]		1.2 [2.6]	1.4 [3.1]	1.5 [3.3]	1.4 [3.1]	1.8 [4.0]	3.7 [8.2]	3.8 [8.4]	5.3 [12]	5.4 [12]	11 [24]	11 [24]			

(*1) Standard applicable motor indicates Fuji Electric 4-pole standard motors. Select a motor not only based on inverter output (kW), but also so that the output rated current is greater than the motor rated current.
 (*2) The rated capacity indicates 220 V for the 200V series, and 440 V for the 400V series.
 (*3) It is not possible to output a voltage higher than the power supply voltage.
 (*4) Setting the carrier frequency (F26) to the following value or above requires current derating.
 HHD spec. of types FRN0002E3□-4G to FRN0012E3□-4G : 8 kHz, FRN0022E3□-4G to FRN0072E3□-4G; 10 kHz
 HND spec. of types FRN0002E3□-4G to FRN0012E3□-4G : 8 kHz, FRN0022E3□-4G to FRN0059E3□-4G; 10 kHz, FRN0072E3□-4G; 6 kHz
 HD / ND spec. of types FRN0002E3□-4G to FRN0072E3□-4G; 4 kHz
 (*5) This indicates the estimated value if the power supply capacity is 500 kVA (10 times inverter capacity if inverter capacity exceeds 50 kVA), and the motor is connected to a power supply of %X = 5%.
 (*6) This indicates the capacity when the motor is equipped with a DC reactor (DCR).
 (*7) This is the average braking torque when performing individual operation. (This will vary based on the motor efficiency.)
 (*8) Interphase unbalance ratio [%] = (Max. voltage [V] - min. voltage [V]) / Three-phase average voltage [V] x 67 (see IEC/EN 61800-3). If using the motor with an unbalance ratio of 2 to 3%, use an AC reactor (ACR: option).
 (*9) For FRN0007/0012E3S-4G, FRN0007/0012E3N-4G HND specifications, If the ambient temperature is 40°C or higher, the output current must be derated by 1%/°C.

Features
Main application examples
Model variations
Type number nomenclature
Standard specifications
Common specifications
Terminal specifications
Basic wiring diagram
External dimensions
Keypad
Function codes
Options
Product warranty

Standard specifications

Three-phase 400V

EMC filter built-in type

Item		Specification													
Type(FRN□□□□E3E-4G)		0002	0004	0006	0007 *9	0012 *9	0022	0029	0037	0044	0059	0072			
Standard applicable motor *1	HHD	kW	0.4	0.75	1.5	2.2	3.7	5.5	7.5	11	15	18.5	22		
		HP	1/2	1	2	3	5	7.5	10	15	20	25	30		
	HND	kW	0.75	1.1	2.2	3	5.5	7.5	11	15	18.5	22	30		
		HP	1	1.5	3	4	7.5	10	15	20	25	30	40		
	HD	kW	0.75	1.1	2.2	3	5.5	7.5	11	15	18.5	22	30		
		HP	1	1.5	3	4	7.5	10	15	20	25	30	40		
	ND	kW	0.75	1.5	2.2	3	5.5	11	15	18.5	22	30	37		
		HP	1	2	3	4	7.5	15	20	25	30	40	50		
Output ratings	Rated capacity [kVA] *2		HHD	1.1	1.9	3.2	4.2	7.0	11	14	18	24	30	34	
			HND	1.4	2.6	3.8	4.8	8.5	13	18	27	31	34	46	
			HD	1.4	2.6	3.8	4.8	8.5	13	18	24	29	34	46	
			ND	1.6	3.1	4.2	5.3	9.1	16	22	28	34	45	55	
	Rated voltage [V] *3		Three-phase 400 to 480 V (with AVR function)												
	Rated current [A] *4		HHD	1.5	2.5	4.2	5.5	9.2	14.8	18	24	31	39	45	
			HND	1.8	3.4	5	6.3	11.1	17.5	23	35	41	45	60	
			HD	1.8	3.4	5	6.3	11.1	17.5	23	35	41	45	60	
			ND	2.1	4.1	5.5	6.9	12	21.5	28.5	37	44	59	72	
	Overload current rating [A] (permissible overload time)		HHD	150% for 1 minute, 200% for 0.5 seconds											
			HND	120% for 1 minute											
			HD	150% for 1 minute											
ND			120% for 1 minute												
Ambient temperature		HHD	-10 to +55 ° C [14 to 131 ° F] (current derating necessary in +50 to +55 ° C [122 to 131 ° F] range)												
		HND	-10 to +55 ° C [14 to 131 ° F] (current derating necessary in +50 to +55 ° C [122 to 131 ° F] range) Type of 0007 to 0012 -10 to +50 ° C [14 to 122 ° F] (current derating necessary in +40 to +50 ° C [104 to 122 ° F] range)												
		HD	-10 to +50 ° C [14 to 122 ° F] (current derating necessary in +40 to +50 ° C [104 to 122 ° F] range)												
		ND	-10 to +50 ° C [14 to 122 ° F] (current derating necessary in +40 to +50 ° C [104 to 122 ° F] range)												
Rated frequency [Hz]		50 / 60 Hz													
Voltage, frequency		Three-phase 200 to 240 V, 50/60 Hz													
Voltage, frequency fluctuation		Voltage: +10 to -15% (interphase unbalance ratio: 2% or less) *8, Frequency: +5 to -5 %													
Input ratings	Rated current [A] *5		With DCR	HHD	0.85	1.6	3	4.4	7.3	10.6	14.4	21.1	28.8	35.5	42.2
				HND	1.5	2.1	4.2	5.8	10.1	14.4	21.1	28.8	35.5	42.2	57
				HD	1.5	2.1	4.2	5.8	10.1	14.4	21.1	28.8	35.5	42.2	57
				ND	1.5	2.9	4.2	5.8	10.1	21.1	28.8	35.5	42.2	57	68.5
	Without DCR	HHD	1.7	3.1	5.9	8.2	13	17.3	23.2	33	43.8	52.3	60.6		
		HND	2.7	3.9	7.3	11.3	16.8	23.2	33	43.8	52.3	60.6	77.9		
		HD	2.7	3.9	7.3	11.3	16.8	23.2	33	43.8	52.3	60.6	77.9		
		ND	2.7	4.8	7.3	11.3	16.8	33	43.8	52.3	60.6	77.9	94.3		
	Required power supply capacity (with DCR) [kVA] *6		HHD	0.6	1.2	2.1	3.1	5.1	7.3	10	15	20	25	29	
			HND	1.1	1.5	3	4.1	7	10	15	20	25	29	39	
HD			1.1	1.5	3	4.1	7	10	15	20	25	29	39		
ND			1.1	2.1	3	4.1	7	15	20	25	29	39	47		
Auxiliary control power supply voltage		-										Single-phase 380 to 480 V, 50/60 Hz			
Braking	Torque *7		HHD	100%		70%		40%		20%					
			HND	53%	68%	48%	29%	27%	15%						
			HD	53%	68%	48%	29%	27%	15%						
			ND	53%	50%	48%	29%	27%	12%						
	Braking transistor		Built-in												
Connectable resistance value [Ω]		200			160 to 200			130 to 200	80 min.	60 min.	40 min.	34.4 min.	16 min.		
Braking resistor [Ω]		Option													
EMC filter(E3E)		Compliant with EMC Directives. Emission: Category C2. Immunity: 2nd Env. (EN61800-3)						Compliant with EMC Directives. Emission: Category C3. Immunity: 2nd Env. (EN61800-3)							
DC reactor (DCR)		Option													
Protective construction (IEC 60529)		IP20 enclosed type, UL open type													
Cooling system		Natural cooling						Fan cooling							
Weight [kg(lbs)]		1.5 [3.3]	1.7 [3.7]	2.0 [4.4]	2.2 [4.9]	2.2 [4.9]	5.3 [12]	5.4 [12]	7.5 [17]	7.5 [17]	11 [24]	12 [26]			

(*1) Standard applicable motor indicates Fuji Electric 4-pole standard motors. Select a motor not only based on inverter output (kW), but also so that the output rated current is greater than the motor rated current.
(*2) The rated capacity indicates 220 V for the 200V series, and 440 V for the 400V series.
(*3) It is not possible to output a voltage higher than the power supply voltage.
(*4) Setting the carrier frequency (F26) to the following value or above requires current derating.
HHD spec. of types FRN0002E3□-4G to FRN0012E3□-4G 8 kHz FRN0022E3□-4G to FRN0072E3□-4G 10 kHz
HND spec. of types FRN0002E3□-4G to FRN0012E3□-4G 8 kHz FRN0022E3□-4G to FRN0059E3□-4G 10 kHz FRN0072E3□-4G 6 kHz
HD / ND spec. of types FRN0002E3□-4G to FRN0072E3□-4G 4 kHz
(*5) This indicates the estimated value if the power supply capacity is 500 kVA (10 times inverter capacity if inverter capacity exceeds 50 kVA), and the motor is connected to a power supply of %X = 5%.
(*6) This indicates the capacity when the motor is equipped with a DC reactor (DCR).
(*7) This is the average braking torque when performing individual operation. (This will vary based on the motor efficiency.)
(*8) Interphase unbalance ratio [%] = (Max. voltage [V] - min. voltage [V]) / Three-phase average voltage [V] x 67 (see IEC/EN 61800-3).
If using the motor with an unbalance ratio of 2 to 3%, use an AC reactor (ACR: option).

Single-phase 200V

Basic type

Item			Specification						
Type(FRN□□□□E3S-7G)*10			0001	0002	0004 *11	0006 *11	0010 *11	0012 *11	
Standard applicable motor *1	HHD	kW	0.1	0.2	0.4	0.75	1.5	2.2	
		HP	1/8	1/4	1/2	1	2	3	
	HND	kW	0.2	0.4	0.55	1.1	2.2 *8	3 *9	
		HP	1/4	1/2	3/4	1.5	3	4	
Output ratings	Rated capacity [kVA] *2		HHD	0.4	0.6	1.1	1.9	3.0	4.2
			HND	0.5	0.7	1.3	2.3	3.7	4.6
	Rated voltage [V] *3		Three-phase 200 to 240 V (with AVR function)						
	Rated current [A] *4		HHD	1	1.6	3	5	8	11
			HND	1.2	1.9	3.5	6	9.6	12
	Overload current rating [A] (permissible overload time)		HHD	150% for 1 minute, 200% for 0.5 seconds					
			HND	120% for 1 minute					
	Ambient temperature		HHD	-10 to +55 °C [14 to 131 °F] (current derating necessary in +50 to +55 °C [122 to 131 °F] range)					
			HND	-10 to +55 °C [14 to 131 °F] (current derating necessary in +50 to +55 °C [122 to 131 °F] range) Type of 0004 to 0012 -10 to +50 °C [14 to 122 °F] (current derating necessary in +40 to +50 °C [104 to 122 °F] range)					
	Rated frequency [Hz]		50 / 60 Hz						
Input ratings	Voltage, frequency		Three-phase 200 to 240 V, 50/60 Hz						
	Voltage, frequency fluctuation		Voltage: +10 to -10% (interphase unbalance ratio: 2% or less) , Frequency: +5 to -5 %						
	Rated current [A] *5	With DCR	HHD	1.1	2	3.5	6.4	11.6	17.5
			HND	2.2	3.7	4.6	9.4	17.9	25
		Without DCR	HHD	1.8	3.3	5.4	9.7	16.4	22
			HND	3.3	4.9	7.3	13.8	20.2	26
	Required power supply capacity (with DCR) [kVA] *6		HHD	0.3	0.4	0.7	1.3	2.4	3.5
			HND	0.5	0.8	1.0	1.9	3.6	5.0
Auxiliary control power supply voltage		-							
Braking	Torque *7		HHD	150%		100%		70%	40%
			HND	75%		73%	68%	48%	29%
	Braking transistor		Built-in						
	Connectable resistance value [Ω]		100 to 120				40 to 120		
Braking resistor [Ω]		Option							
DC reactor (DCR)		Option							
Protective construction (IEC 60529)		IP20 enclosed type, UL open type							
Cooling system		Natural cooling				Fan cooling			
Weight [kg(lbs)]		0.5 [1.1]	0.5 [1.1]	0.6 [1.3]	0.9 [2.0]	1.4 [3.1]	1.7 [3.7]		

(*1) Standard applicable motor indicates Fuji Electric 4-pole standard motors. Select a motor not only based on inverter output (kW), but also so that the output rated current is greater than the motor rated current.

(*2) The rated capacity indicates 220 V for the 200V series, and 440 V for the 400V series.

(*3) It is not possible to output a voltage higher than the power supply voltage.

(*4) Setting the carrier frequency (F26) to the following value or above requires current derating.

HHD spec.: 8 kHz

HND spec.: 4 kHz

(*5) This indicates the estimated value if the power supply capacity is 500 kVA (10 times inverter capacity if inverter capacity exceeds 50 kVA), and the motor is connected to a power supply of %X = 5%.

(*6) This indicates the capacity when the motor is equipped with a DC reactor (DCR).

(*7) This is the average braking torque when performing individual operation. (This will vary based on the motor efficiency.)

(*8) Input voltage is less than 220V, standard applicable motor is 2.0kW.

(*9) Input voltage is less than 220V, standard applicable motor is 2.7kW.

(*10) HND specifications, set F80-4.

(*11) For FRN0004E3S-7G to FRN0012E3S-7G, FRN0004E3N-7G to FRN0012E3N-7G HND specifications. If the ambient temperature is 40°C or higher, the output current must be derated by 2%/°C.

Features

Main application examples

Model variations

Type number nomenclature

Standard specifications

Common specifications

Terminal specifications

Basic wiring diagram

External dimensions

Keypad

Function codes

Options

Product warranty

Standard specifications

Single-phase 200V

Ethernet built-in type

Item			Specification						
Type(FRN□□□□E3N-7G)*10			0001	0002	0004 *11	0006 *11	0010 *11	0012 *11	
Standard applicable motor *1	HHD	kW	0.1	0.2	0.4	0.75	1.5	2.2	
		HP	1/8	1/4	1/2	1	2	3	
	HND	kW	0.2	0.4	0.55	1.1	2.2 *8	3 *9	
		HP	1/4	1/2	3/4	1.5	3	4	
Output ratings	Rated capacity [kVA] *2		HHD	0.4	0.6	1.1	1.9	3.0	4.2
			HND	0.5	0.7	1.3	2.3	3.7	4.6
	Rated voltage [V] *3		Three-phase 200 to 240 V (with AVR function)						
	Rated current [A] *4		HHD	1	1.6	3	5	8	11
			HND	1.2	1.9	3.5	6	9.6	12
	Overload current rating [A] (permissible overload time)		HHD	150% for 1 minute, 200% for 0.5 seconds					
			HND	120% for 1 minute					
	Ambient temperature		HHD	-10 to +55 °C [14 to 131 °F] (current derating necessary in +50 to +55 °C [122 to 131 °F] range)					
			HND	-10 to +55 °C [14 to 131 °F] (current derating necessary in +50 to +55 °C [122 to 131 °F] range) Type of 0004 to 0012 -10 to +50 °C [14 to 122 °F] (current derating necessary in +40 to +50 °C [104 to 122 °F] range)					
	Rated frequency [Hz]		50 / 60 Hz						
Input ratings	Voltage, frequency		Three-phase 200 to 240 V, 50/60 Hz						
	Voltage, frequency fluctuation		Voltage: +10 to -10% (interphase unbalance ratio: 2% or less) , Frequency: +5 to -5 %						
	Rated current [A] *5	With DCR	HHD	1.1	2	3.5	6.4	11.6	17.5
		HND	2.2	3.7	4.6	9.4	17.9	25	
		Without DCR	HHD	1.8	3.3	5.4	9.7	16.4	22
		HND	3.3	4.9	7.3	13.8	20.2	26	
	Required power supply capacity (with DCR) [kVA] *6		HHD	0.3	0.4	0.7	1.3	2.4	3.5
		HND	0.5	0.8	1.0	1.9	3.6	5.0	
Auxiliary control power supply voltage		-							
Braking	Torque *7		HHD	150%		100%		70%	40%
			HND	75%		73%	68%	48%	29%
	Braking transistor		Built-in						
	Connectable resistance value [Ω]		100 to 120				40 to 120		
Braking resistor [Ω]		Option							
DC reactor (DCR)		Option							
Protective construction (IEC 60529)		IP20 enclosed type, UL open type							
Cooling system		Natural cooling				Fan cooling			
Weight [kg(lbs)]		0.5 [1.1]	0.5 [1.1]	0.7 [1.5]	0.9 [2.0]	1.5 [3.3]	1.7 [3.7]		

(*1) Standard applicable motor indicates Fuji Electric 4-pole standard motors. Select a motor not only based on inverter output (kW), but also so that the output rated current is greater than the motor rated current.

(*2) The rated capacity indicates 220 V for the 200V series, and 440 V for the 400V series.

(*3) It is not possible to output a voltage higher than the power supply voltage.

(*4) Setting the carrier frequency (F26) to the following value or above requires current derating.

HHD spec.: 8 kHz

HND spec.: 4 kHz

(*5) This indicates the estimated value if the power supply capacity is 500 kVA (10 times inverter capacity if inverter capacity exceeds 50 kVA), and the motor is connected to a power supply of %X = 5%.

(*6) This indicates the capacity when the motor is equipped with a DC reactor (DCR).

(*7) This is the average braking torque when performing individual operation. (This will vary based on the motor efficiency.)

(*8) Input voltage is less than 220V, standard applicable motor is 2.0kW.

(*9) Input voltage is less than 220V, standard applicable motor is 2.7kW.

(*10) HND specifications, set F80-4.

(*11) For FRN0004E3S-7G to FRN0012E3S-7G, FRN0004E3N-7G to FRN0012E3N-7G HND specifications. If the ambient temperature is 40°C or higher, the output current must be derated by 2%/°C.

Single-phase 200V

EMC filter built-in type

Item			Specification							
Type(FRN□□□□E3E-7G)			0001	0002	0004	0005	0008	0011		
Standard applicable motor *1	HHD	kW	0.1	0.2	0.4	0.75	1.5	2.2		
		HP	1/8	1/4	1/2	1	2	3		
Rated capacity [kVA] *2		HHD	0.4	0.6	1.1	1.9	3.0	4.2		
Rated voltage [V] *3		Three-phase 200 to 240 V (with AVR function)								
Rated current [A] *4		HHD	1	1.6	3	5	8	11		
Overload current rating [A] (permissible overload time)		HHD	150% for 1 minute, 200% for 0.5 seconds							
Ambient temperature		HHD	-10 to +55 °C [14 to 131 °F] (current derating necessary in +50 to +55 °C [122 to 131 °F] range)							
Rated frequency [Hz]		50 / 60 Hz								
Voltage, frequency		Three-phase 200 to 240 V, 50/60 Hz								
Voltage, frequency fluctuation		Voltage: +10 to -10% (interphase unbalance ratio: 2% or less) , Frequency: +5 to -5 %								
Input ratings	Rated current [A] *5	With DCR	HHD	1.1	2	3.5	6.4	11.6	17.5	
		Without DCR	HHD	1.8	3.3	5.4	9.7	16.4	22	
	Required power supply capacity (with DCR) [kVA] *6		HHD	0.3	0.4	0.7	1.3	2.4	3.5	
Auxiliary control power supply voltage		-								
Braking	Torque *7		HHD	150%		100%		70%	40%	
	Braking transistor		Built-in							
	Connectable resistance value [Ω]		100 to 120				40 to 120			
	Braking resistor [Ω]		Option							
DC reactor (DCR)		Option								
EMC filter(E3E)		Compliant with EMC Directives. Emission: Category C2. Immunity: 2nd Env. (EN61800-3)								
Protective construction (IEC 60529)		IP20 enclosed type, UL open type								
Cooling system		Natural cooling						Fan cooling		
Weight [kg(lbs)]			0.6 [1.3]	0.6 [1.3]	0.8 [1.8]	1.2 [2.6]	2.0 [4.4]	2.2 [4.9]		

(*1) Standard applicable motor indicates Fuji Electric 4-pole standard motors. Select a motor not only based on inverter output (kW), but also so that the output rated current is greater than the motor rated current.

(*2) The rated capacity indicates 220 V for the 200V series, and 440 V for the 400V series.

(*3) It is not possible to output a voltage higher than the power supply voltage.

(*4) Setting the carrier frequency (F26) to the following value or above requires current derating.

HHD 8 kHz

HND 4 kHz

(*5) This indicates the estimated value if the power supply capacity is 500 kVA (10 times inverter capacity if inverter capacity exceeds 50 kVA), and the motor is connected to a power supply of %X = 5%.

(*6) This indicates the capacity when the motor is equipped with a DC reactor (DCR).

(*7) This is the average braking torque when performing individual operation. (This will vary based on the motor efficiency.)

(*8) Input voltage is less than 220V, standard applicable motor is 2.0kW.

(*9) Input voltage is less than 220V, standard applicable motor is 2.7kW.

(*10) HND specifications, set F80=4.

(*11) EMC filter built-in type is only available in HHD specification.

Features

Main application examples

Model variations

Type number nomenclature

Standard specifications

Common specifications

Terminal specifications

Basic wiring diagram

External dimensions

Keypad

Function codes

Options







Product warranty

Common Specifications

Item		Description		Remarks	
Output	Maximum output frequency	5 to 599 Hz (If the output frequency exceeds 599 Hz, the inverter will stop with overspeed protection.) If Vector control with speed sensor, this is determined by the maximum PG option card input frequency, number of motor poles, and number of encoder poles.			
	Base frequency	5 to 599 Hz variable			
	Number of motor poles setting	2 to 128 poles			
	Starting frequency	0.1 to 60.0 Hz variable (0.0 Hz under vector control)			
	Carrier frequency	FRN***E3S/N-2G - 0.75 to 16 kHz variable setting	HHD specification : **** =	0001 ~ 0115	
			HND specification : **** =	0001 ~ 0010 0030 ~ 0088	
		- 0.75 to 10 kHz variable setting	HND specification : **** = 0012 ~ 0020 0115		
			FRN***E3S/N/E-4G - 0.75 to 16 kHz variable setting	HHD specification : **** =	
		HND specification : **** =		0002 ~ 0059	
		- 0.75 to 10 kHz variable setting	HD specification : **** =	0002 ~ 0059	
- 0.75 to 6 kHz variable setting	HND specification : **** =	0072			
	HD specification : **** =	0072			
ND specification : **** =	0002 ~ 0059				
ND specification : **** =	0072				
FRN***E3S/N-7G - 0.75 to 16 kHz variable setting - 0.75 to 10 kHz variable setting	HHD specification : **** = 0001 ~ 0012 HND specification : **** = 0001 ~ 0012				
FRN***E3E-7G - 0.75 to 16 kHz variable setting	HHD specification : **** = 0001 ~ 0011				
Note) The carrier frequency may automatically lower depending upon the ambient temperature or the output current to protect the inverter. (The automatic lowering function can be disabled.)					
Frequency setting resolution	<ul style="list-style-type: none"> Analog setting: 1/3000 of maximum output frequency Digital setting: 0.01 Hz (99.99 Hz or less), 0.1 Hz (100.0 to 599.0 Hz) Link setting: 0.005% of maximum frequency or 0.01 Hz (fixed) 				
Induction motors	During sensor-equipped V/f control ¹⁾ During sensor-equipped dynamic torque vector control ²⁾	Speed control range	<ul style="list-style-type: none"> •1:20¹·1:200²⁾ (Minimum speed: Base speed) •1:2 (Constant torque region: Constant power region) 		
		Speed control accuracy	<ul style="list-style-type: none"> •Analog settings : Within ±0.2% of the maximum output frequency (25 ±10°C) •Digital settings : Within ±0.01% of the maximum output frequency (-10 to +50°C) 		
	During sensorless vector control	Speed control range	<ul style="list-style-type: none"> •1:200 (Minimum speed: Base speed) •1:2 (Constant torque region: Constant power region) 		
		Speed control accuracy	<ul style="list-style-type: none"> •Analog settings : Within ±0.5% of the maximum output frequency (25 ±10°C) •Digital settings : Within ±0.5% of the maximum output frequency (-10 to +50°C) 		
	During sensor-equipped vector control	Speed control range	<ul style="list-style-type: none"> •1:1500 (Minimum speed: Base speed) •1:2 (Constant torque region: Constant power region) 		
		Speed control accuracy	<ul style="list-style-type: none"> •Analog settings : Within ±0.2% of the maximum output frequency (25 ±10°C) •Digital settings : Within ±0.01% of the maximum output frequency (-10 to +50°C) 		
	Synchronous motors	During sensorless vector control	Speed control range	<ul style="list-style-type: none"> •1:10 (Minimum speed: Base speed) •1:2 (Constant torque region: Constant power region) 	
			Speed control accuracy	<ul style="list-style-type: none"> •Analog settings : Within ±0.5% of the Base speed (25 ±10°C) •Digital settings : Within ±0.5% of the Base speed (-10 to +50°C) 	
During sensor-equipped vector control		Speed control range	<ul style="list-style-type: none"> •1:1500 (Minimum speed: Base speed) •1:2 (Constant torque region: Constant power region) 		
		Speed control accuracy	<ul style="list-style-type: none"> •Analog settings : Within ±0.2% of the maximum output frequency (25 ±10°C) •Digital settings : Within ±0.01% of the maximum output frequency (-10 to +50°C) 		
Control	Speed control accuracy Output frequency accuracy	Analog setting : ±0.2% or less of maximum output frequency (at 25 ±10 °C) (77 ±18 °F)		VF IMPG-VF IMPG-DTV IMPG-VC PMPG-VC	
		Digital setting : ±0.01% or less of maximum output frequency (at -10 to +50 °C) (14 to 122 °F)			
		Analog setting : ±0.5% or less of maximum output frequency (at 25 ±10 °C) (77 ±18 °F)		IM-SVC PM-SVC	
		Digital setting : ±0.5% or less of maximum output frequency (at -10 to +50 °C) (14 to 122 °F)			

Note) Depending on the inverter type, specifications may vary.



Refer to the FRENIC-Ace (E3) User's Manual for details.

Item	Description	Remarks
Control method	V/f control	VF
	Dynamic torque vector control	DTV
	V/f control with slip compensation	SCVF
	V/f control with speed sensor (PG option card required)	IMPG-VF *2
	Dynamic torque vector control with speed sensor (PG option card required)	IMPG-DTV *2
	Vector control with speed sensor (PG option card required)	IMPG-VC *2
	Vector control without speed sensor	IM-SVC
	Vector control with magnetic pole position sensor (PG option card required)	PMPG-VC *2
Voltage / frequency characteristics	Vector control without magnetic pole position sensor	PM-SVC
	- The base frequency and maximum output frequency are common, and the voltage can be set between 80 and 240 V (200V series) and 160 and 500 V (400V series). - Linear V/f setting (3 points) : The voltage can be set freely from 0 to 240 V (200V series) and 0 to 500 V (400V series), and the frequency can be set from 0 to 599 Hz. - AVR control can be turned ON or OFF.	
Torque boost	- Auto torque boost (for constant torque load) - Manual torque boost: The torque boost value can be set between 0.0 and 20.0%. - The applicable load can be selected. (for constant torque load, quadratic-torque load)	
Starting torque (HHD specifications)	At 200% or higher/Setting frequency 0.5 Hz or higher, V/f control (base frequency 50 Hz, slip compensation, automatic torque boost)	
Running operation	- Key operation : Run/stop with  and  keys (standard keypad) Run/stop with  /  and  keys (multi-function keypad: option)	*2
	- External signals : Forward (reverse) rotation run/stop commands [2-wire/3-wire operation], (digital input "HLD", "DIR", "FWD", "REV") coast to stop command, external alarm, alarm reset, etc.	*2
	- Link setting : Setting by RS-485 communication (E3S), Setting by field bus communication (Option : E3S / Built-in : E3N)	
	- Run command switching : Remote/local switching, link switching	*2
Frequency settings	- Keypad : Setting possible with  /  keys	*2
	- External potentiometer : Using external frequency command potentiometer (external resistor of 1 to 5 kΩ, 1/2 W)	
	- Analog input : -10 to +10 VDC (-5 to +5 VDC) / -100 to +100% (terminal [12]) 0 to +10 VDC (0 to +5 VDC)/0 to +100% (terminal [12], [C1] (V2 function)) 0 to +10 VDC (0 to +5 VDC)/-100 to +100% (terminal [12], [C1] (V2 function)) 4 to 20 mA DC/0 to 100% (terminal [C1] (C1 function)) 4 to 20 mA DC/-100 to 0 to 100% (terminal [C1] (C1 function)) 0 to 20 mA DC/0 to 100% (terminal [C1] (C1 function)) 0 to 20 mA DC/-100 to 0 to 100% (terminal [C1] (C1 function)) [C1 function] and [V2 function] of terminal [C1] cannot be used at the same time. (exclusive)	
	- UP/DOWN operation: Frequency can be increased or decreased while the digital "UP" or "DOWN" signals are ON. It is possible to select whether to record or clear the current frequency when the power is turned OFF. The frequency recorded with digital input "STZ" can be cleared.	
	- Multistep frequency selection : Selectable from 16 different frequencies (step 0 to 15)	
	- Pattern operation : The inverter can be run automatically according to the previously specified run time, rotation direction, acceleration / deceleration time and reference frequency. Up to 7 stages can be set.	
	- Link setting1 Setting is possible with RS-485 communication (built-in as standard). Setting is possible with field bus communication (option:E3S / Built-in:E3N).	
	- Frequency setting switching : The frequency setting can be switched between two types with an external signal (digital input "Hz2/Hz1"). Remote/local switching ("LOC") and link switching ("LE") are also possible.	*2
	- Auxiliary frequency setting : Terminal [12] and [C1] inputs can be selected as the auxiliary frequency setting and added to the main settings.	
	- Operation at specified ratio : A ratio value can be set with analog input signals (terminal [12] and [C1]). 0 to 10 VDC/4(0) to 20 mA/0 to 200% (variable)	
	Inverse operation : The following settings can be specified with external commands (terminals) : - Can be switched from "0 to +10 VDC/0 to 100%" to "+10 to 0 VDC/0 to 100%" (terminal [12] / [C1] (V2 function)). - Can be switched from "0 to -10 VDC/0 to -100%" to "-10 to 0 VDC/0 to -100%" (terminal [12] / [C1] (V2 function)). - Can be switched from "4 to 20 mA DC / 0 to 100%" to "20 to 4 mA DC / 0 to 100%" (terminal [C1] (C1 function)). - Can be switched from "0 to 20 mA DC / 0 to 100%" to "20 to 0 mA DC / 0 to 100%" (terminal [C1] (C1 function)).	
	- Pulse train input (standard) : Pulse input "PIN" = Terminal [X5], rotational direction "SIGN" = input terminal other than [X5]. - Maximum input pulse When connected to complementary output transmitter: 100 kHz When connected to open collector output transmitter: 30 kHz	*2

Note) Depending on the inverter type, specifications may vary.

Refer to the FRENIC-Ace (E3) User's Manual for details.

Common Specifications

Item	Description	Remarks
Frequency settings	<ul style="list-style-type: none"> Pulse train input (option): A PG option is required. CW / CCW pulse, pulse + rotation direction - Maximum input pulse When connected to complementary output transmitter: 100 kHz When connected to open collector output transmitter: 30 kHz 	*2
Acceleration / deceleration time	<ul style="list-style-type: none"> - Setting range : 0.00 to 6000 seconds - Switching : The four types of acceleration/deceleration time can be set or selected individually (switchable during operation). - Acceleration/deceleration pattern : Linear acceleration/deceleration, S-curve acceleration/deceleration (week, Arbitrary), Curvilinear acceleration/deceleration (max. acceleration/deceleration at rated output) - Deceleration mode (coast to stop) : Coast to stop when run command turned OFF. - Deceleration time for forced stop : Deceleration stop in exclusive deceleration time by forced stop (STOP). During forced stop operation, S-curve acceleration/deceleration is disabled. - Dedicated acceleration/deceleration time for jogging - It is possible to switch between acceleration/deceleration time = 0 with acceleration/deceleration operation cancel "BPS". 	
Frequency limiter (upper limit, lower limit frequency)	<ul style="list-style-type: none"> - Both the upper limit frequency and lower limit frequency are set in Hz values. - "Continue to run" or "Decelerate to a stop" selectable when the reference frequency drops below the lower limit. (disabled under vector control) - Setting is possible with analog input (terminal [12], [C1]). 	
Frequency/ PID command bias	<ul style="list-style-type: none"> The frequency setting and PID command bias can be set independently. Frequency setting: (setting range: 0 to ±200%) PID command (setting range: 0 to ±100%) 	
Analog input	<ul style="list-style-type: none"> - Gain: Setting range: 0 to 400% - Offset: Setting range from -5.0 to +5.0% - Filter: Setting range: 0.00 s to 5.00 s - Polarity selection (selection possible from ± or +) 	
Jump frequency	Six points and their common jump width (0 to 30.0 Hz) can be set.	
Timed operation	The inverter runs and stops for only the operating time set with the keypad. (1 cycle operation)	*2
Jogging operation	<ul style="list-style-type: none"> - Operation with  key (standard keypad),  /  keys (multi-function keypad), digital contact inputs FWD/REV or digital contact inputs "FWD", "REV" (dedicated acceleration time individual setting, dedicated frequency setting) - Jogging operation can be performed with independent commands "FJOG" for forward rotation jogging and "RJOG" for reverse rotation jogging without "FWD", "REV". 	*2
Auto-restart after momentary power failure	<ul style="list-style-type: none"> - Trip after power failure : Immediate trip after power failure - Trip after power restoration : Motor coasts to a stop after power failure, and trip occurs after power restoration. - Trip after deceleration stop : Motor decelerates and stops after power failure, and trips after stopping. - Continue to run : Load inertia energy is used to continue operation. - Start at frequency selected before momentary power failure : Motor coasts to stop after power failure, and starts at frequency at time of power failure after power restoration. - Start at starting frequency : Motor coasts to stop after power failure, and starts at starting frequency after power restoration. - Start at frequency selected after power restoration : Motor coasts to stop after power failure, searches for speed and restarts after power restoration. 	
Current limiting (hardware current limiter)	Current is limited with hardware to prevent overcurrent trip due to high-speed load fluctuations or momentary power failure which cannot be handled with software current limiting. (This limiter can be canceled.)	
Current limiting (software current limiter)	<ul style="list-style-type: none"> - Automatically reduces the frequency so that the output current becomes lower than the preset operation level. (This limiter can be canceled.) - The operation can be selected (operation at constant speed only, operation when accelerating and at constant speed). 	
Operation by commercial power supply	<ul style="list-style-type: none"> - 50/60 Hz can be output with a switch to commercial power supply command ("SW50", "SW60"). - A commercial switching sequence is built in. 	
Slip compensation	<ul style="list-style-type: none"> - Motor slip is compensated to keep the motor speed to a reference speed, regardless of the load torque. - The slip compensation responsiveness (time constant) can be adjusted. 	
Droop control	- This function is used to adjust the speed of each motor individually to balance load torque on machines driven with multiple motor systems.	
Torque limiting Torque current limiting Power limiting	<ul style="list-style-type: none"> The output torque or output torque current is controlled so that the output torque is equal to or less than the limiting value set beforehand. - The value can be switched between torque limit value 1 and torque limit value 2. - Torque limit values can be set individually for each of the four quadrants. - Torque limiting and torque current limiting can be selected. - Torque limiting is possible with analog input. 	IMPG-VC PMPG-VC PM-SVC
Overload stop	<ul style="list-style-type: none"> - If the detected torque or current exceeds the preset value, the motor can be stopped with a deceleration stop or coast to stop, or when contact is made with the stopper. - Operating conditions can be set in operation mode (while the motor is running at constant speed and while decelerating/while the motor is running at constant speed/all modes). - The torque during stopper contact can be adjusted. 	

Note) Depending on the inverter type, specifications may vary.

Refer to the FRENIC-Ace (E3) User's Manual for details.

Item	Description	Remarks
PID control	<ul style="list-style-type: none"> - PID controller for process control/dancer control - Normal/inverse operation switching - Commands: keypad, analog input (terminal [12], [C1]), multi-step settings (selection possible from 3 points), RS-485 communication, field bus communication (Option : E3S/E3E / Built-in : E3N) - Feedback values: analog input (terminal [12], [C1]) - Alarm output (absolute value alarm, deviation alarm) - Low liquid level stop function (pressurized operation possible before low liquid level stop) - Anti-reset wind-up function - Output limiter - Integral/differential reset/integral hold function - PID constant auto tuning function for process control PID controller 	
Retry	<ul style="list-style-type: none"> - Even if a protective function subject to a retry is triggered, an attempt is made to automatically cancel the trip condition up to the number of set times to resume operation without outputting an integrated alarm. - The number of attempts can be set up to 20 times (can be set with function code) 	
Auto search	The motor speed is estimated before startup, and the motor is started without ever stopping the motor while it is idling. (Motor constant tuning required : offline tuning)	
Anti-regenerative control	<ul style="list-style-type: none"> - If the DC link bus voltage/torque calculation value reach or exceed the anti-regenerative control level when the motor is decelerating, the deceleration time is automatically extended to avoid an overvoltage trip. (Forced deceleration can be set at three or more times the deceleration time.) - If the torque calculation value reaches or exceeds the anti-regenerative control level during constant speed operation, overvoltage tripping is avoided by performing control to raise the frequency. 	
Deceleration characteristic (improved braking ability)	<ul style="list-style-type: none"> - During deceleration, this function increases the motor energy loss and decreases the regenerative energy returned to avoid an overvoltage trip. - Setting is also possible when using in combination with AVR cancel.) 	
Auto energy saving operation	Controls the output voltage in order to minimize the total motor and inverter power loss at constant speed.	
Overload prevention control	If the surrounding temperature or IGBT junction temperature increases due to an overload, the inverter lowers the output frequency to avoid an overload.	
Battery operation	Cancels the undervoltage protection so that the inverter under an undervoltage condition runs the motor with battery power. (FRN008E3□-2G,FRN0115E3□-2G,FRN0059E3□-4G,FRN0072E3□-4G)	
Offline tuning	<ul style="list-style-type: none"> - Measures the motor constant when the motor is stopped or rotating, and sets it in a motor constant function code. (IM motors, PM motors) - Mode in which IM motor %R1 and %X only are tuned 	
	Mode in which PM motor magnetic pole position offset is tuned	PMPG-VC *2
Online tuning	Automatically adjusts motor parameters while the motor is running to prevent fluctuations in motor speed due to rises in motor temperature.	DTV
Cooling fan ON-OFF control	<ul style="list-style-type: none"> - Detects inverter internal temperature and stops cooling fan when the temperature is low. - Available to output a fan control signal to an external device. 	
Motor 1 ,2 settings	<ul style="list-style-type: none"> - Switching is possible between 2 motors. - It is possible to set the base frequency, rated current, torque boost, electronic thermal slip compensation, ASR, notch filter, starting frequency, stopping frequency, thermistor operation selection, and speed display coefficients, etc. as the data for motors 1 to 2. - Cumulative motor run count, start count 	
Motor selection	Equipped with parameters for Fuji standard motors. Optimum motor parameters can be set by setting the type and capacity. <ul style="list-style-type: none"> - Fuji standard motors, 8-series - Typical HP unit motors - Fuji premium efficiency motors (MLK1/MUL1 series) - Fuji synchronous motors (GNB2 series, GNP1 series) 	
Universal DI	Transfers the status of an external digital signal connected with the general-purpose digital input terminal to the host controller.	
Universal DO	Outputs a digital command signal sent from the host controller to the general-purpose digital output terminal.	
Universal AO	Outputs an analog command signal sent from the host controller to the analog output terminal.	
Speed control	<ul style="list-style-type: none"> - Selectable among the four set of the auto speed regulator (ASR) parameters. - A vibration suppression notch filter can be set. (for IMPG-VC, PMPG-VC only) (A PG option card is required.) 	MPG-VF IMPG-DTV IMPG-VC IM-SVC PMPG-VC PM-SVC *2
Line speed control	Regulates the motor speed to keep the peripheral speed constant even if the roll winding diameter changes on machines such as winders and unwinders. Tension can be controlled when used in combination with PID control. (A PG option card is required.)	IMPG-VF IMPG-DTV IMPG-VC *2
Master-follower operation	Two motors can be run synchronously using a pulse generator (PG). (A PG option card is required.)	IMPG-VF IMPG-DTV IMPG-VC *2
Pre-excitation	<ul style="list-style-type: none"> - Excitation is carried out to create the motor flux before starting the motor. (A PG option card is required.) 	IMPG-VC IM-SVC *2
Zero speed control	<ul style="list-style-type: none"> - Zero speed control is performed by forcibly zeroing the speed command. (A PG option card is required.) 	IMPG-VC PMPG-VC *2
Servo lock	Stops the inverter and holds the motor at the stopped position. (A PG option card is required.)	IMPG-VC PMPG-VC *2
DC braking	- Applies DC current to the motor at the operation start time or at the time of inverter stop to generate braking torque.	
Mechanical brake control	<ul style="list-style-type: none"> - It is possible to output mechanical brake control signals with the brake ON/OFF timing adjusted by the output current, torque commands, output frequency and timer. - The output timing of control signals can be adjusted individually when performing forward rotation (hoisting) and reverse rotation (lowering). - Errors can be detected with mechanical brake operation check input signals. 	Other than PM-SVC

Note) Depending on the inverter type, specifications may vary.





Refer to the FRENIC-Ace (E3) User's Manual for details.

Common Specifications

	Item	Description	Remarks
Control	Torque control	- Analog torque commands/torque current commands possible - Speed limit function is provided to prevent the motor from becoming out of control. - Torque bias (with analog setting, digital setting) possible	IMPG-VC IM-SVC PMPG-VC
	Rotation direction restriction	Select either of reverse or forward rotation prevention.	
	Condensation prevention	Current flows automatically when the motor is stopped, and the motor temperature is raised to prevent condensation.	
	Customization logic	It is possible to select or connect digital logic circuits or analog operation circuits with digital/analog I/O signals, configure a simple relay sequence, and operate it freely. (Max. of 260 steps)	
	Positioning control	Feedback pulses are counted from the preset count start point, and the motor automatically decelerates to the creep speed and stops at the target stop point. (A PG option card is required.)	IMPG-VF IMPG-DTV IMPG-VC *2
	Orientation function	Positioning function of rotating bodies such as the main axes and turntables of machine tools Capable of setting stop target position using function codes (8 points) (PG option card required)	
	Favorites Function code	The function codes can be registered in "Favorites" and displayed. (Applicable to all function codes)	*2
	Data initialization	All function codes and limited function codes can be initialized. (related to each motor parameter, the exception of communication function, related to the customizable logic, registered in "Favorites")	
	Start check function	To ensure safety, it is available to check for the existence of run commands when turning the power ON, when resetting alarms, and when changing the run command method, and display an alarm if a run command has been input.	
	Destination setting	The factory default values such as voltage, frequency, and other function codes can be changed based on whether the machine is being shipped for use in Japan, Asia, China, Europe, USA, Taiwan, or East Asia. This setting is not necessary for Japanese model or Chinese model.	
Multifunction key	During the operation mode the "SHIFT" key on standard keypads (TP-M3) and "M/SHIFT" key on option keypad (TP-E2) can be used as an input source to activate the input terminal function like the X terminal. Any function is not assigned as a factory default.		
Display	During operation and stop	Speed monitor (set frequency, output frequency, motor rotation speed, load rotation speed, feed speed (line speed), % display speed), output current [A], output voltage [V], torque calculation value [%], power consumption [kW], PID command value, PID feedback value, PID output, load factor [%], motor output [kW], torque current (%), flux command (%) analog input monitor, cumulative power, constant dimension feed time [min], remaining time when timer operation is enabled [s], etc.	
	Cumulative operating conditions	- Displays cumulative inverter operating time, cumulative electric energy (watt-hours), and cumulative motor operating time/ startup count (by motor) - Outputs a forecast when the preset maintenance time and startup count are exceeded	
	When trip occurs	Shows the cause of a trip	
	When warning appears	- Shows a warning cause. - When the cause is removed, it is recorded in the warning history and the display disappears. - Stores and displays the cause (code) for up to the past 6 alarms in the light alarm history.	
	During operation and trip	- The cause up to The last ten faults can be stored and displayed with codes. - Details of all relevant data when a fault occurs is also stored and displayed for up to The last four faults. - Capable of displaying the date in the history by using the clock function (TP-A2SW)	
Protective/detecting functions	Inverter lifetime alarm	- Deterioration diagnosis can be carried out for main circuit capacitors, electrolytic capacitors on PCBs, cooling fans, and IGBTs. lifetime alarms can be displayed, and data can be output externally. - Warning information can be displayed and output externally if the maintenance time or startup count set beforehand is exceeded. - Operating temperature: 40 °C (104 °F)	*2
	Overcurrent protection	Stops the inverter to protect it from overcurrent caused by an overload.	
	Short circuit protection	Stops if the inverter detects an overcurrent due to a short circuit in the output circuit.	OC 1 OC2 OC3
	Ground fault protection	Stops if the inverter detects an overcurrent due to a short circuit in the output circuit. It may not be detected at powered if an inverter output is under the ground fault status.	
	Overvoltage protection	Stops the inverter if a DC link bus circuit overvoltage (400V series: 800 VDC, 200V series: 400 VDC) is detected. The inverter cannot be protected if an excessively large voltage is applied by accident.	OU 1 OU2 OU3
	Undervoltage protection	Stops the inverter if a drop in DC link bus voltage (400V series: 400 VDC, 200V series: 200 VDC) is detected. However, this is disabled based on the restart after momentary power failure setting. Furthermore, operation is possible (regenerative operation only) at a voltage level lower than that above when performing battery operation.	LU
	Input phase loss protection	Stops the inverter if input phase loss or input phase voltage unbalance is detected. The input phase loss protection may not work under light load or with DC reactor.	L in
	Output phase loss protection	Stops the inverter if inverter output phase loss is detected during operation. This protective function also functions during auto tuning and during magnetic pole position tuning. (Operation selection possible)	OPL
	Overheat protection	Stops the inverter if a cooling fan fault, or cooling fin overheating when an overload occurs is detected.	OH 1
		Stops the inverter if a cooling fan fault, or inverter unit internal overheating when an overload occurs is detected.	OH3
		Stops the inverter if inverter unit internal charging resistor overheating is detected.	OH6
		By setting the braking resistor electronic thermal overload relay function, the inverter is stopped to protect the braking resistor from overheating.	dbH
	Inverter overload protection	Stops the inverter if overheating is detected by calculating the IGBT internal temperature from the output current and detected internal temperature.	OLU
	External alarm input	Stops the inverter and displays an error if a digital input signal (THR) is input.	OH2
	Charging circuit fault	Stops the inverter and displays an error if an inverter charging circuit error is detected.	PbF
	Braking transistor fault	Stops the inverter and displays an error if a braking transistor error is detected.	dbR
	Motor protection	Motor 1 overload Motor 2 overload (Electronic thermal)	Stops the inverter if a motor overload is detected by setting the electronic thermal. Protects general-purpose motors and inverter motors in the entire frequency range. (The operation level and thermal time constant (0.5 to 75.0 minutes) can be set.)
PTC thermistor		The motor temperature is detected by the PTC thermistor, and the inverter is stopped if overheating is detected. To enable this function, connect the PTC thermistor between terminals [C1] and [11], and enable the switch on the control board.	OH4
Memory error	When the power is turned ON, a data check is performed when writing data, and an error is displayed if a memory error is detected.	Er 1	

Note) Depending on the inverter type, specifications may vary.

Refer to the FRENIC-Ace (E3) User's Manual for details.

Item	Description	Remarks
Keypad communication error	Stops the inverter and displays an error if a communication fault is detected at the keypad during operation.	<i>Er2</i>
CPU error	Stops the inverter and displays an error if a CPU error is detected due to noise, etc.	<i>Er3</i>
Option communication error	Stops the inverter and displays an error if a communication error with the inverter unit is detected when using an option.	<i>Er4</i>
Option error	Stops the inverter and displays an error if an error is detected at the option side when using an option.	<i>Er5</i>
Operation error	 key priority Even when run commands are entered via the terminal block or communication, by pressing the keypad  key, the inverter forcibly decelerates and stops the motor, and an error is displayed after the motor has come to a stop.	<i>Er6</i>
	Start check When the power is turned ON, an alarm is cleared, or when switching the run command method from link operation, the sudden starting of operation is suppressed if a run command has been entered, and an error is displayed to notify the operator.	
	Brake status error Stops the inverter and displays an error if the brake signal (BRKS) output status and brake ON check signal (BRKE) input status do not match.	
Tuning error	Stops the inverter and displays an error if tuning failure or interruption is detected during motor constant tuning, or if the tuning result is a defect.	<i>Er7</i>
RS485 communication error (COM port 1)	Stops the inverter and displays an error if a communication error is detected when communicating via RS-485 COM port 1.	<i>Er8</i>
RS485 communication error (COM port 2)	Stops the inverter and displays an error if a communication error is detected when communicating via RS-485 COM port 2.	<i>Er9</i>
Data saving error during undervoltage	Stops the inverter and displays an error if unable to successfully save data when undervoltage protection is triggered.	<i>ErF</i>
Position control error	Stops the inverter and displays an error if the positioning deviation is excessive when the servo lock is applied, or when performing master-follower operation.	<i>Er0</i>
Hardware error	Stops the inverter and displays an error if an inverter internal hardware fault is detected.	<i>ErH</i>
STO input (EN1, EN2) terminal circuit fault	Stops the inverter and displays an error if the inverter detects an EN1 or EN2 terminal circuit mismatch.	<i>ErI</i>
PG wire break	Stops the inverter and displays an error if a pulse encoder wire break is detected. (This function is valid on some PG interface option cards.)	<i>PG</i>
Excessive positioning deviation	Stops the inverter and displays an error if the position deviation is found to be excessive while performing position control.	<i>d0</i>
Overspeed protection	Stops the inverter and displays an error if the following conditions are met. - If d35 = 999, the speed detection value is the maximum output frequency x (d32 or d33) x 120% or higher - If d35 ≠ 999, the speed detection value is the maximum output frequency x (d35) or higher - The detected speed exceeds 599 Hz	<i>05</i>
Magnetic pole position detection error	Stops the inverter and displays an error if the signal from the magnetic pole position sensor mounted on the PM motor is abnormal.	<i>ErC</i>
Step-out detection/detection failure of magnetic pole position at start	This occurs when a PM motor step-out is detected, or if magnetic pole position at start failed to be detected.	<i>ErD</i>
Speed mismatch or excessive speed deviation	Stops the inverter and displays an error if an excessive deviation appears between the reference speed and detected/estimated speed.	<i>ErE</i>
Password protection	Stops the inverter and displays an error if a malicious person tries to unlock the password set by the customer.	<i>LoP</i>
Customizable logic error	Stops the inverter and displays an alarm when the alarm condition defined by the customer in the customizable logic is met. (It is not an alarm related to the inverter faults)	<i>ErL</i>
Simulation fault	A simulation fault can be produced if the keypad  key and  key are held down for 5 seconds or longer. A simulation fault can be produced even if function code H45 is set to "1".	<i>Err</i>
Current input terminal signal wire break detection	Stops the inverter and displays an alarm if a current input wire break is detected when current is less than 2 mA when using the current input terminal (terminal [C1] or [C2]) as current input 4 to 20 mA.	<i>LoF</i>
Customizable logic alarm	An error is displayed if the alarm conditions defined by the user with customizable logic are met. (This is not an error at the inverter itself.)	<i>ErA ErS</i>
EN (STO) terminal OFF	This is displayed if the run command turns ON when both terminal [EN1] and [EN2] are OFF, and the inverter is not ready to perform operation (STO status).	<i>..En</i>
Warning	Motor overload early warning	<i>0L</i>
	Motor overload early warning	<i>0H</i>
	Cooling fin overheat early warning	<i>LIF</i>
	Lifetime warning	<i>rEF</i>
	Reference command loss detected	<i>Pid</i>
	PID warning output	<i>uFL</i>
	Overheat warning by PTC thermistor in motor	<i>PfC</i>
	Machine life (Cumulative motor running hours)	<i>rFE</i>
	Inverter life (Number of startups)	<i>EnI</i>
IGBT lifetime warning	<i>iGb</i>	
Retry	The inverter can be automatically reset allowing it to be restarted when it stops due to a trip. (The number of retries and the latency between stop and reset can be specified.)	
Surge protection	This function protects the inverter from a surge voltage between main circuit power lines and the ground.	

Note) Depending on the inverter type, specifications may vary.

*1 : The items in this table are displayed in the LED display on the LED keypad. Refer to the multi-function keypad.

*2 : Some functions cannot be used with E3N.

Refer to the FRENIC-Ace (E3) User's Manual for details.

Specification	Representative function
Keypad connection	Running operation and frequency settings by keypad, Timed operation, Remote/local switching, Display/change of function code setting value, display of various monitor items
Pulse train input PG interface card	Frequency setting by pulse train, Mototr control with speed sensor, Positioning control, Orientation function, Servo lock

Common Specifications

Item	Description	Remarks												
Main circuit power cutoff detection	Inverter operation is not possible when the inverter AC input power supply (main power supply) is not ON. In such cases as when supplying power via a PWM converter or when using a DC bus bar connection, set main circuit power cutoff detection to "None".													
Forced operation (Fire mode)	Alarms other than critical alarms are ignored, and a retry is performed forcibly.	<i>F_{od}</i>												
Installation location	Indoors													
Ambient temperature	[FRN-E3S(Basic Type), FRN-E3N(Ethernet built-in Type), FRN-E3E(EMC filter built-in type)] HHD : -10 to +55 °C [14 to 131 °F] (current derating necessary in +50 to +55 °C [122 to 131 °F] range) HND : -10 to +55 °C [14 to 131 °F] (current derating necessary in +50 to +55 °C [122 to 131 °F] range) -10 to +50 °C [14 to 122 °F] (current derating necessary in +40 to +50 °C [104 to 122 °F] range) FRN0012E3□-2G, FRN0020E3□-2G, FRN0007E3□-4G, FRN0012E3□-4G, FRN0004E3□-7G, FRN0006E3□-7G, FRN0010E3□-7G, FRN0012E3□-7G HD / ND : -10 to +50 °C [14 to 122 °F] (current derating necessary in +40 to +50 °C [104 to 122 °F] range) When installed closely side-by-side HHD : -10 to +40 °C [14 to 104 °F] HND : -10 to +40 °C [14 to 131 °F] -10 to +30 °C [14 to 122 °F] FRN0012E3□-2G, FRN0020E3□-2G, FRN0007E3□-4G, FRN0012E3□-4G, FRN0004E3□-7G, FRN0006E3□-7G, FRN0010E3□-7G, FRN0012E3□-7G HD / ND : -10 to +30 °C [14 to 86 °F]													
Relative humidity	5 to 95% RH (there should no condensation)													
Atmosphere	The inverter must not be exposed to dust, direct sunlight, corrosive or flammable gases, oil mist, vapor, water drops or vibration. (Pollution degree 2 (IEC60664-1)) The atmosphere must contain only a low level of salt. (0.01 mg/cm ² or less per year) There should be no condensation due to sudden temperature changes.													
Altitude	1000 m (3300 ft) or lower If used in a location with altitude of 1000 m (3300 ft) or higher, do so after reducing the output current as shown in the following table.													
	<table border="1"> <thead> <tr> <th>Altitude</th> <th>Output current derating factor</th> </tr> </thead> <tbody> <tr> <td>1000 m or lower (3300 ft or lower)</td> <td>1.00</td> </tr> <tr> <td>1000 to 1500 m (3300 to 4900 ft)</td> <td>0.97</td> </tr> <tr> <td>1500 to 2000 m (4,900 to 6600 ft)</td> <td>0.95</td> </tr> <tr> <td>2000 to 2500 m (6600 to 8200 ft)</td> <td>0.91</td> </tr> <tr> <td>2500 to 3000 m (8200 to 9800 ft)</td> <td>0.88</td> </tr> </tbody> </table>	Altitude	Output current derating factor	1000 m or lower (3300 ft or lower)	1.00	1000 to 1500 m (3300 to 4900 ft)	0.97	1500 to 2000 m (4,900 to 6600 ft)	0.95	2000 to 2500 m (6600 to 8200 ft)	0.91	2500 to 3000 m (8200 to 9800 ft)	0.88	
Altitude	Output current derating factor													
1000 m or lower (3300 ft or lower)	1.00													
1000 to 1500 m (3300 to 4900 ft)	0.97													
1500 to 2000 m (4,900 to 6600 ft)	0.95													
2000 to 2500 m (6600 to 8200 ft)	0.91													
2500 to 3000 m (8200 to 9800 ft)	0.88													
Vibration	<table border="1"> <thead> <tr> <th>Type</th> <th>2 to less than 9 Hz</th> <th>9 to less than 20 Hz</th> <th>20 to less than 55 Hz</th> <th>55 to 200 Hz</th> </tr> </thead> <tbody> <tr> <td>FRN0001E3□-2G to FRN0115E3□-2G</td> <td rowspan="3">3mm (max. amplitude)</td> <td rowspan="3">9.8m/s²</td> <td rowspan="3">5.9m/s²</td> <td rowspan="3">1m/s²</td> </tr> <tr> <td>FRN0002E3□-4G to FRN0072E3□-4G</td> </tr> <tr> <td>FRN0001E3□-7G to FRN0012E3□-7G</td> </tr> </tbody> </table>	Type	2 to less than 9 Hz	9 to less than 20 Hz	20 to less than 55 Hz	55 to 200 Hz	FRN0001E3□-2G to FRN0115E3□-2G	3mm (max. amplitude)	9.8m/s ²	5.9m/s ²	1m/s ²	FRN0002E3□-4G to FRN0072E3□-4G	FRN0001E3□-7G to FRN0012E3□-7G	
Type	2 to less than 9 Hz	9 to less than 20 Hz	20 to less than 55 Hz	55 to 200 Hz										
FRN0001E3□-2G to FRN0115E3□-2G	3mm (max. amplitude)	9.8m/s ²	5.9m/s ²	1m/s ²										
FRN0002E3□-4G to FRN0072E3□-4G														
FRN0001E3□-7G to FRN0012E3□-7G														
Storage temperature (Note 1)	-25 to +70 °C (during transport) (-13 to +158 °F) -25 to +65 °C (during temporary storage) (-13 to +149 °F) -10 to +30 °C (during long-term storage) (14 to 86 °F)	Places not subjected to condensation or freezing due to sudden temperature changes												
Relative humidity (Note 2)	During temporary storage: 5 to 95% RH (there should no condensation) During long-term storage: 5 to 70% RH													
Atmosphere	The inverter must not be exposed to dust, direct sunlight, corrosive or flammable gases, oil mist, vapor, water drops or vibration. The atmosphere must contain only a low level of salt. (0.01 mg/cm ² or less per year)													
Atmospheric pressure	86 to 106 kPa (during storage) 70 to 106 kPa (during transport)													

Refer to the FRENIC-Ace (E3) User's Manual for details.

Terminal Specifications

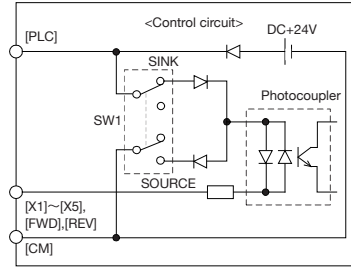
Class	Symbol	Terminal name	Explanation	E3S	E3E	E3N																									
Main circuit	L1/R, L2/S, L3/T	Main power supply input terminals	Connect a three-phase power supply.																												
	R0, T0	Auxiliary control power input terminals	There is normally no need to use these terminals. If wishing to retain the integrated alarm signal issued if the protective function is triggered even when the inverter main power supply is cut off, or to constantly display the keypad, connect control power auxiliary input terminals to a power supply. If connecting a PWM converter, do not connect the power supply directly to the inverter control power auxiliary input terminals (R0, T0).	Remarks: FRN0088E3□-2G FRN0115E3□-2G FRN0059E3□-4G FRN0072E3□-4G																											
	U, V, W	Inverter output terminals	Connect three-phase motor terminals U, V, and W to match the phase sequence.																												
	P1, P(+)	DC reactor connection terminals	Connect a DC reactor (DCR) (option) for power-factor improvement.																												
	P(+), N(-)	DC link bus connection terminals	Connect braking unit terminals P(+) and N(-). Furthermore, DC link bus circuit of other inverters and PWM converters can be connected.																												
	P(+), DB	Braking resistor connection terminals	Connect terminals P(+) and DB of the inverter to braking resistor terminals (option).																												
⊕G	Inverter grounding terminal	This is a grounding terminal for the inverter chassis (case). Be sure to ground grounding terminals to ensure safety, and as a noise countermeasure.																													
Analog input	[13]	Power supply for potentiometer	Power supply for frequency setting (+10 VDC) (Potentiometer: 1 to 5 kΩ) Connect a potentiometer with rating of 1/2 W or higher.	○	○	○																									
	[12]	Analog setting voltage input	(1) Specify the frequency based on the external voltage input. - 0 to ±10 VDC/0 to ±100% (normal operation) - +10 to 0 VDC/0 to 100% (inverse operation) (2) In addition to frequency settings, PID commands, PID feedback signals, auxiliary frequency command settings, ratio settings, torque limiter level settings, and analog input monitors, etc. can be assigned to this terminal. (3) Hardware specifications - Input impedance: 22 kΩ - The maximum input is ±15 VDC, but is handled as ±10 VDC for voltages greater than ±10 VDC.	○	○	○																									
	[C1]	Analog setting current input (C1 function)	(1) The frequency is specified based on the external current input. - 4(0) to 20 mA DC/0 to 100% (normal operation) - 20 to 4(0) mA DC/0 to 100% (inverse operation) (2) In addition to frequency settings, PID commands, PID feedback signals, auxiliary frequency command settings, ratio settings, torque limiter level settings, and analog input monitors, etc. can be assigned to this terminal. (3) Hardware specifications - Input impedance: 250 Ω - The maximum input is +30 mA DC, but is handled as +20 mA DC for currents greater than +20 mA DC. (4) If using this function, set SW3 to the "C1" side, SW4 to the "AI" side.	○	○	○																									
	[C1]	Analog setting voltage input (V2 function)	(1) Specify the frequency based on the external voltage input. - 0 to ±10 VDC/0 to ±100% (normal operation) - +10 to 0 VDC/0 to 100% (inverse operation) (2) In addition to frequency settings, PID commands, PID feedback signals, auxiliary frequency command settings, ratio settings, torque limiter level settings, and analog input monitors, etc. can be assigned to this terminal. (3) Hardware specifications - Input impedance: 22 kΩ - The maximum input is +15 VDC, but is handled as +10 VDC for voltages greater than +10 VDC. (4) If using this function, set SW3 to the "V2" side, SW4 to the "AI" side.	○	○	○																									
	[C1]	PTC thermistor input	(1) PTC (Positive Temperature Coefficient) thermistors are connected for motor protection. (2) If using this function, set SW3 to the "C1" side, SW4 to the "PTC" side.	○	○	○																									
	[11]	Analog common	This is a common terminal for analog input signals (terminals [13], [12], [C1], [FM1], and [FM2]). This terminal is isolated from terminals [CM] and [CMY].	○	○	○																									
Digital input	[X1]	Digital input 1	(1) Various signals (coast to stop command, external alarms, multistep frequency selection, etc.) can be set for terminals [X1] to [X5], [FWD], and [REV]. (2) The input mode and SINK/SOURCE can be switched using SW1. (3) The operating mode between each digital input terminal and terminal [CM] can be switched to "ON when shorted (active ON)" or "OFF when shorted (active OFF)". (4) Digital input terminals [X5] can be set up as pulse train input terminals by changing the function code. - When connected to complementary output pulse generator: max. 100 Hz - When connected to open collector output pulse generator: max. 30 Hz (A pull-up resistor and pull-down resistor are required.)	○	○	○																									
	[X2]	Digital input 2		○	○	○																									
	[X3]	Digital input 3		○	○	○																									
	[X4]	Digital input 4		○	○	○																									
	[X5]	Digital input 5		○	○	○																									
	[FWD]	Forward rotation/stop command Input	○	○	○																										
	[REV]	Reverse rotation/stop command Input	<p><Digital input circuit specifications></p>  <table border="1"> <thead> <tr> <th>Item</th> <th></th> <th>Min.</th> <th>Max.</th> </tr> </thead> <tbody> <tr> <td rowspan="2">Operating voltage (SINK)</td> <td>ON level</td> <td>0 V</td> <td>2 V</td> </tr> <tr> <td>OFF level</td> <td>20 V</td> <td>27 V</td> </tr> <tr> <td rowspan="2">Operating voltage (SOURCE)</td> <td>ON level</td> <td>20 V</td> <td>27 V</td> </tr> <tr> <td>OFF level</td> <td>0 V</td> <td>2 V</td> </tr> <tr> <td>Operating current when ON (X5 input terminal)</td> <td></td> <td>2.5 mA (9.7 mA)</td> <td>5 mA (16 mA)</td> </tr> <tr> <td>Permissible leakage current when OFF</td> <td></td> <td>-</td> <td>0.5 mA</td> </tr> </tbody> </table>	Item		Min.	Max.	Operating voltage (SINK)	ON level	0 V	2 V	OFF level	20 V	27 V	Operating voltage (SOURCE)	ON level	20 V	27 V	OFF level	0 V	2 V	Operating current when ON (X5 input terminal)		2.5 mA (9.7 mA)	5 mA (16 mA)	Permissible leakage current when OFF		-	0.5 mA	○	○
Item		Min.	Max.																												
Operating voltage (SINK)	ON level	0 V	2 V																												
	OFF level	20 V	27 V																												
Operating voltage (SOURCE)	ON level	20 V	27 V																												
	OFF level	0 V	2 V																												
Operating current when ON (X5 input terminal)		2.5 mA (9.7 mA)	5 mA (16 mA)																												
Permissible leakage current when OFF		-	0.5 mA																												

*1 These specifications and functions are useful during sensorless vector control.

*2 These specifications and functions are useful during sensor-equipped vector control. However, an optional PG interface card is required.



Refer to the FRENIC-Ace (E3) User's Manual for details.

Features
Main application examples
Model variations
Type number nomenclature
Standard specifications
Common specifications
Terminal specifications
Basic wiring diagram
External dimensions
Keypad
Function codes
Options
Product warranty

Terminal Specifications

Class	Symbol	Terminal name	Explanation	E3S	E3E	E3N															
Digital input	[EN1] [EN2]	Enable input 1 Enable input 2	<p>(1) By opening the circuit between terminals [EN1] and [PLC], or between terminals [EN2] and [PLC], inverter output transistor operation is stopped by the IEC/EN 61800-5-2-compliant STO safety stop function.</p> <p>(2) The input mode for terminals [EN1] and [EN2] is fixed at SOURCE mode.</p> <p>(3) If either [EN1] or [EN2] is OFF, and an alarm occurs.</p> <p>(4) SW9 enables and disables the STO function. If using the STO function, set SW9 to the "OFF" side.</p> <p><[EN1][EN2] input circuit specifications></p> <table border="1"> <thead> <tr> <th>Item</th> <th>Min.</th> <th>Max.</th> </tr> </thead> <tbody> <tr> <td rowspan="2">Operating voltage (SOURCE)</td> <td>ON level</td> <td>20 V</td> </tr> <tr> <td>OFF level</td> <td>0 V</td> </tr> <tr> <td>Operating current when ON (when input voltage 27 V)</td> <td>—</td> <td>4.5 mA</td> </tr> <tr> <td>Permissible leakage current when OFF</td> <td>—</td> <td>0.5 mA</td> </tr> </tbody> </table>	Item	Min.	Max.	Operating voltage (SOURCE)	ON level	20 V	OFF level	0 V	Operating current when ON (when input voltage 27 V)	—	4.5 mA	Permissible leakage current when OFF	—	0.5 mA	○	○	○	
	Item	Min.	Max.																		
	Operating voltage (SOURCE)	ON level	20 V																		
OFF level		0 V																			
Operating current when ON (when input voltage 27 V)	—	4.5 mA																			
Permissible leakage current when OFF	—	0.5 mA																			
[PLC]	Programmable controller signal power supply	<p>(1) Connect the output signal power supply for the programmable controller. (Rated voltage +24 VDC (power supply voltage fluctuation range: +20.4 to +27 VDC), maximum 100 mA DC)</p> <p>(2) The terminal can also be used as the power supply for loads connected to transistor outputs.</p>	○	○	○																
[CM]	Digital common	This is a common terminal for digital input signals. The terminal is insulated from terminals [11] and [CMY].	○	○	○																
Digital input	[FM1]	Analog monitor 1 FMV function FMI function	<p>- Both terminals output analog DC voltage (0 to ±10 V) or analog DC current (4(0) to 20 mA) monitor signals.</p> <p>- The output form (FMV/FMI) is switched using SW5 on the PCB and function code F29.</p> <p>- Select the signal content from the following items according to the data setting of function code F31.</p> <table border="1"> <tbody> <tr> <td>- Output frequency</td> <td>- Power consumption</td> <td>- Motor output</td> </tr> <tr> <td>- Output current</td> <td>- PID feedback value</td> <td>- Analog output test</td> </tr> <tr> <td>- Output voltage</td> <td>- Speed (PG feedback value)</td> <td>- PID command value</td> </tr> <tr> <td>- Output torque</td> <td>- DC intermediate circuit voltage</td> <td>- PID output</td> </tr> <tr> <td>- Load factor</td> <td>- Universal AO</td> <td>- Synchronous angular deviation</td> </tr> </tbody> </table> <p>*Connectible impedance: Minimum 5 kΩ (at 0 to +10 VDC output) (Can connect up to two analog voltmeters (0 to 10 VDC, input impedance of 10 kΩ)) *Connectible impedance: Maximum 500 Ω (at 4 mA to 20 mA DC output) * Gain adjustment range: 0 to 300%</p>	- Output frequency	- Power consumption	- Motor output	- Output current	- PID feedback value	- Analog output test	- Output voltage	- Speed (PG feedback value)	- PID command value	- Output torque	- DC intermediate circuit voltage	- PID output	- Load factor	- Universal AO	- Synchronous angular deviation	○	○	○
	- Output frequency	- Power consumption	- Motor output																		
	- Output current	- PID feedback value	- Analog output test																		
- Output voltage	- Speed (PG feedback value)	- PID command value																			
- Output torque	- DC intermediate circuit voltage	- PID output																			
- Load factor	- Universal AO	- Synchronous angular deviation																			
	Pulse monitor FMP function	Pulse output: 25 to 32000 p/s with full scale, duty of 50%	○	○	○																
[FM2]	Analog monitor 2 FMV function FMI function	<p>- Both terminals output analog DC voltage (0 to ±10 V) or analog DC current (4(0) to 20 mA) monitor signals.</p> <p>- The output form (FMV2/FMI2) is switched using SW7 on the PCB and function code F32.</p> <p>- Select the signal content from the following items according to the data setting of function code F35.</p> <table border="1"> <tbody> <tr> <td>- Output frequency</td> <td>- Power consumption</td> <td>- Motor output</td> </tr> <tr> <td>- Output current</td> <td>- PID feedback value</td> <td>- Analog output test</td> </tr> <tr> <td>- Output voltage</td> <td>- Speed (PG feedback value)</td> <td>- PID command value</td> </tr> <tr> <td>- Output torque</td> <td>- DC intermediate circuit voltage</td> <td>- PID output</td> </tr> <tr> <td>- Load factor</td> <td>- Universal AO</td> <td>- Synchronous angular deviation</td> </tr> </tbody> </table> <p>*Connectible impedance: Minimum 5 kΩ (at 0 to +10 VDC output) (Can connect up to two analog voltmeters (0 to 10 VDC, input impedance of 10 kΩ)) *Connectible impedance: Maximum 500 Ω (at 4 mA to 20 mA DC output) * Gain adjustment range: 0 to 300%</p>	- Output frequency	- Power consumption	- Motor output	- Output current	- PID feedback value	- Analog output test	- Output voltage	- Speed (PG feedback value)	- PID command value	- Output torque	- DC intermediate circuit voltage	- PID output	- Load factor	- Universal AO	- Synchronous angular deviation	○	○	○	
- Output frequency	- Power consumption	- Motor output																			
- Output current	- PID feedback value	- Analog output test																			
- Output voltage	- Speed (PG feedback value)	- PID command value																			
- Output torque	- DC intermediate circuit voltage	- PID output																			
- Load factor	- Universal AO	- Synchronous angular deviation																			
[11]	Analog common	This is a common terminal for analog input/output signals. This terminal is isolated from terminals [CM] and [CMY].	○	○	○																
Transistor output	[Y1]	Transistor output 1	<p>(1) Various signals (running signals, frequency arrival signals, overload early warning signals, etc.) set with function codes E20 to E21 can be output.</p> <p>(2) The operating mode between transistor output terminals [Y1] and [Y2] and terminal [CMY] can be switched to "ON when signal output (active ON)" or "OFF when signal output (active OFF)".</p> <p>(Transistor output circuit specifications)</p> <table border="1"> <thead> <tr> <th>Item</th> <th>Max.</th> </tr> </thead> <tbody> <tr> <td rowspan="2">Operating voltage</td> <td>ON level</td> <td>2 V</td> </tr> <tr> <td>OFF level</td> <td>48 V</td> </tr> <tr> <td>Max. current when ON</td> <td>50 mA</td> </tr> <tr> <td>Leakage current when OFF</td> <td>0.1 mA</td> </tr> </tbody> </table>	Item	Max.	Operating voltage	ON level	2 V	OFF level	48 V	Max. current when ON	50 mA	Leakage current when OFF	0.1 mA	○	○	○				
	Item	Max.																			
	Operating voltage	ON level	2 V																		
OFF level		48 V																			
Max. current when ON	50 mA																				
Leakage current when OFF	0.1 mA																				
[Y2]	Transistor output 2		○	○	○																
[CMY]	Transistor output common	This is a common terminal for transistor output signals. This terminal is isolated from terminals [CM] and [11].	○	○	○																

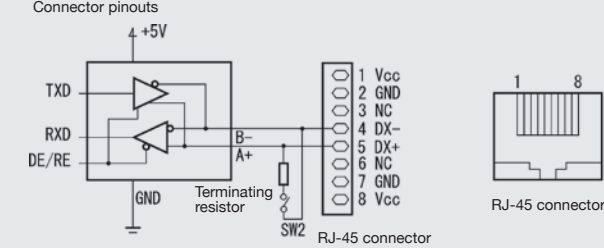
Refer to the FRENIC-Ace (E3) User's Manual for details.

Class	Symbol	Terminal name	Explanation	E3S	E3E	E3N
Relay output	[30A] [30B] [30C]	Integrated alarm output	(1) When the inverter stops with an alarm, an integrated alarm is output at the relay contact (1C). Contact capacity: 250 VAC 0.3 A cosφ = 0.3, 48 VDC 0.5 A (2) The same signals as those of terminals [Y1] to [Y2] can be selected and output. (3) It is possible to switch between a "short circuit between terminals [30A] and [30C] when an ON signal is output (excitation: active ON)" or an "open circuit between terminals [30A] and [30C] when an ON signal is output (non-excitation: active OFF)".	○	○	○
Communication	[DX+] [DX-] [SD]	RS-485 COM port 2 (terminal block)	This is an input/output terminal used to connect a personal computer or programmable controller, etc. by RS-485 communication. Protocols can be selected from the following. - Modbus RTU, dedicated Fuji inverter protocols - Start-stop synchronization, half-duplex method - Max. communication distance: 500 mm - Max. communication speed: 115.2 kbps	○	○	—
	RJ-45 connector Keypad	RS-485 COM port 1 (for keypad connection)	(1) This is used as a connector for connecting the keypad. The keypad power is supplied from the inverter via an extension cable for remote operation. To connect the keypad remotely, the keypad relay adapter CBAD-CP is required separately. (2) This is used to connect a personal computer or programmable controller, etc. by RS-485 communication after disconnecting the keypad. Connector pinouts  Protocols can be selected from the following. - Dedicated keypad protocol (automatically selected) - Modbus RTU, dedicated Fuji inverter protocols - Start-stop synchronization, half-duplex method - Max. communication distance: 20 m (when using RS-485 communication: 500 m) - Max. communication speed: 115.2 kbps(*) (*) The communication speed when the engineering PC tool "FRENIC Loader 4" is connected is automatically adjusted.	○	○	—
	Ethernet RJ-45 connector	Ethernet Port 1 Port 2	This is a connector that connects a programmable controller, etc. via Ethernet communication.	—	—	○
	USB connector	USB port	This is a USB connector (miniB specification) for connecting to a personal computer. Function codes can be edited, transferred, or verified, an inverter test run can be carried out, and all states can be monitored using the engineering PC tool "FRENIC Loader 4". It is possible to edit, transfer, and verify the function code of "FRENIC Loader" with USB bus power.	○	○	○
	Power supply	[P24] [N24]	DC24V input DC24V common	By connecting a power supply to this terminal, Ethernet communication is possible even when the main power supply of the inverter is cut off. The inverter can be operated without inputting power to this terminal. Input voltage range : +22 to +26V DC Current consumption : max.200 mA Common terminal for DC24V	—	—
Grounding terminal		Grounding terminal for Ethernet	This is the terminal that connects the shield part of the Ethernet communication cable to FG, and is connected to the G terminal of the inverter. Keep the cable length as short as possible.	—	—	○

Refer to the FRENIC-Ace (E3) User's Manual for details.

Features
Main application examples
Model variations
Type number nomenclature
Standard specifications
Common specifications
Terminal specifications
Basic wiring diagram
External dimensions
Keypad
Function codes
Options
Product warranty

Basic Wiring Diagram Wiring of main circuit terminal and grounding terminal

Basic type

EMC filter built-in type

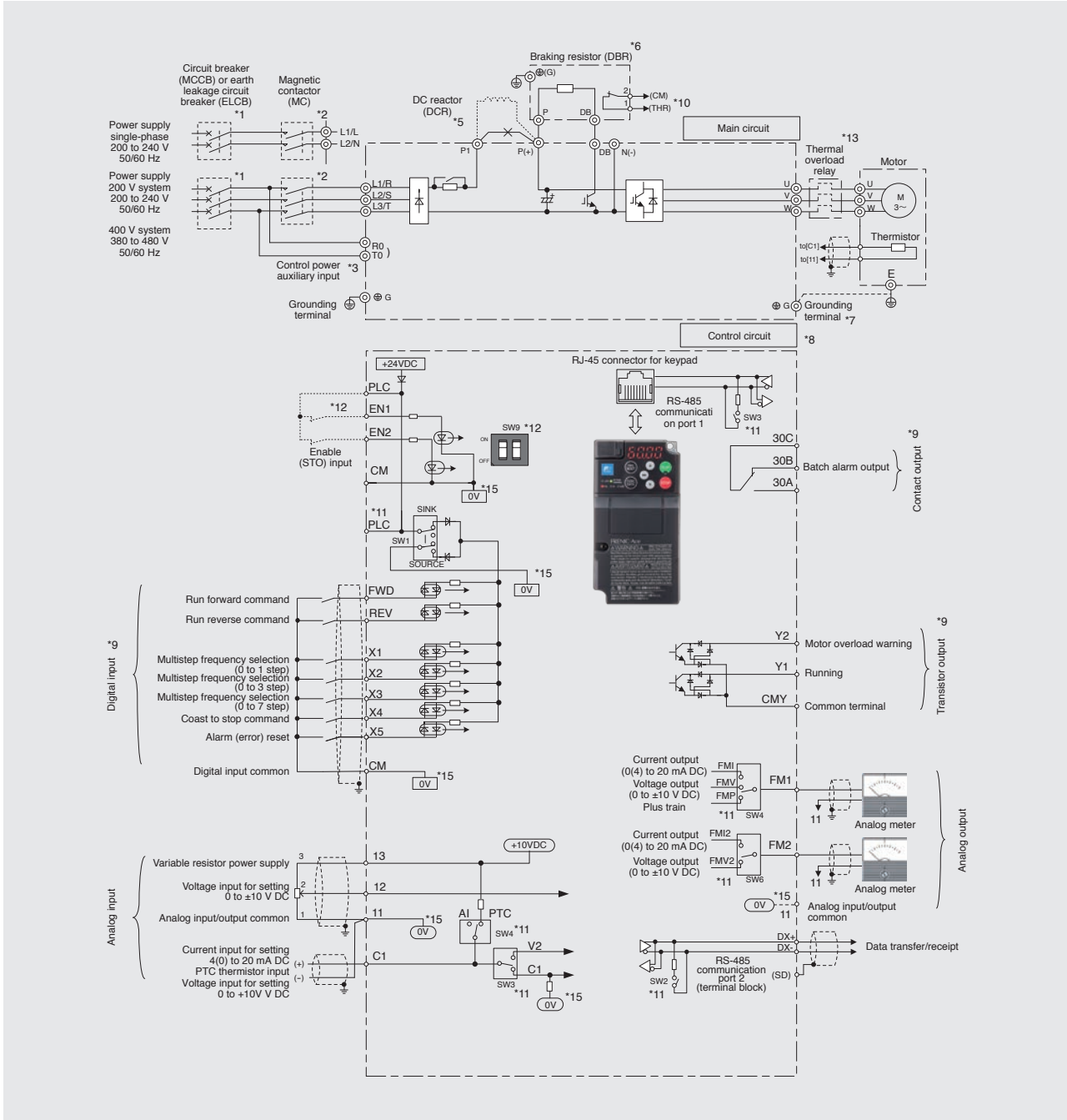

- *1 Install the molded case circuit breaker (MCCB) or earth leakage circuit breaker (ELCB) (with overcurrent protection function) recommended for each inverter on the inverter input side (primary side) to protect wiring. Do not use a circuit breaker that exceeds the recommended rated current.
- *2 An MCCB or ELCB is also used if isolating the inverter from the power supply, and therefore the magnetic contactor (MC) recommended for each inverter should be installed if required. Please note that if installing a coil such as an MC or solenoid near the inverter, connect a surge absorber in parallel.
- *3 If wishing to retain the integrated alarm signal issued if the protective function is triggered even when the inverter main power supply is cut off, or to constantly display the keypad, connect these terminals to the power supply. (on FRN0088E3□-2G or higher / FRN0059E3□-4G or higher) The inverter can be run even without inputting the power supply to these terminals.
- *5 Remove the shorting bar between the inverter main circuit terminals P1 and P(+) before connecting the DC reactor (DCR) (option). Use a DC reactor (DCR) when the capacity of the power supply transformer is 500 kVA or more and is 10 times or more the inverter rated capacity, or when there are "thyristor-driven" loads.
- *6 Inverters are equipped with a built-in braking transistor, allowing direct connection of braking resistors between P(+) and DB.
- *7 This terminal is used for grounding the motor. Connect if required.
- *8 Use twisted wire or shielded wire for control signal lines. Shielded wires are generally grounded, however, if subject to significant induction noise from outside, it may be possible to suppress the effect of the noise by connecting wires to [CM]. Isolate control signal lines from the main circuit wiring as best as possible, and do not run inside the same duct (a distance of 10 cm or greater is recommended.) If lines intersect, ensure that they do so almost perpendicularly to the main circuit wiring.
- *9 Each of the functions described for terminals [FWD] and [REV], terminals [X1] to [X5] (digital input), terminals [Y1] to [Y2] (transistor output), and terminal [30A/B/C] (contact output) indicate functions assigned by factory default.
- *11 These are the switches on control PCBs, and are used to specify settings for inverter operation. Refer to the User's Manual for details.
- *12 Safety function terminals [EN1] and [EN2] are disabled with SW9 (2-pole switch) on the control PCB by factory default. If using this terminal function, be sure to change the respective SW9 switches to the OFF position and connect.
- *13 The thermal overload relay is applicable as necessary. Make the circuit breakers (MCCB) or the magnetic contactors (MC) trip by the thermal relay auxiliary contacts (manual recovery).
- *15 [0V] and [0V] are separated and insulated.
- *17 The CBAD-CP keypad relay adapter is required to connect a remote control cable.

Ethernet built-in type

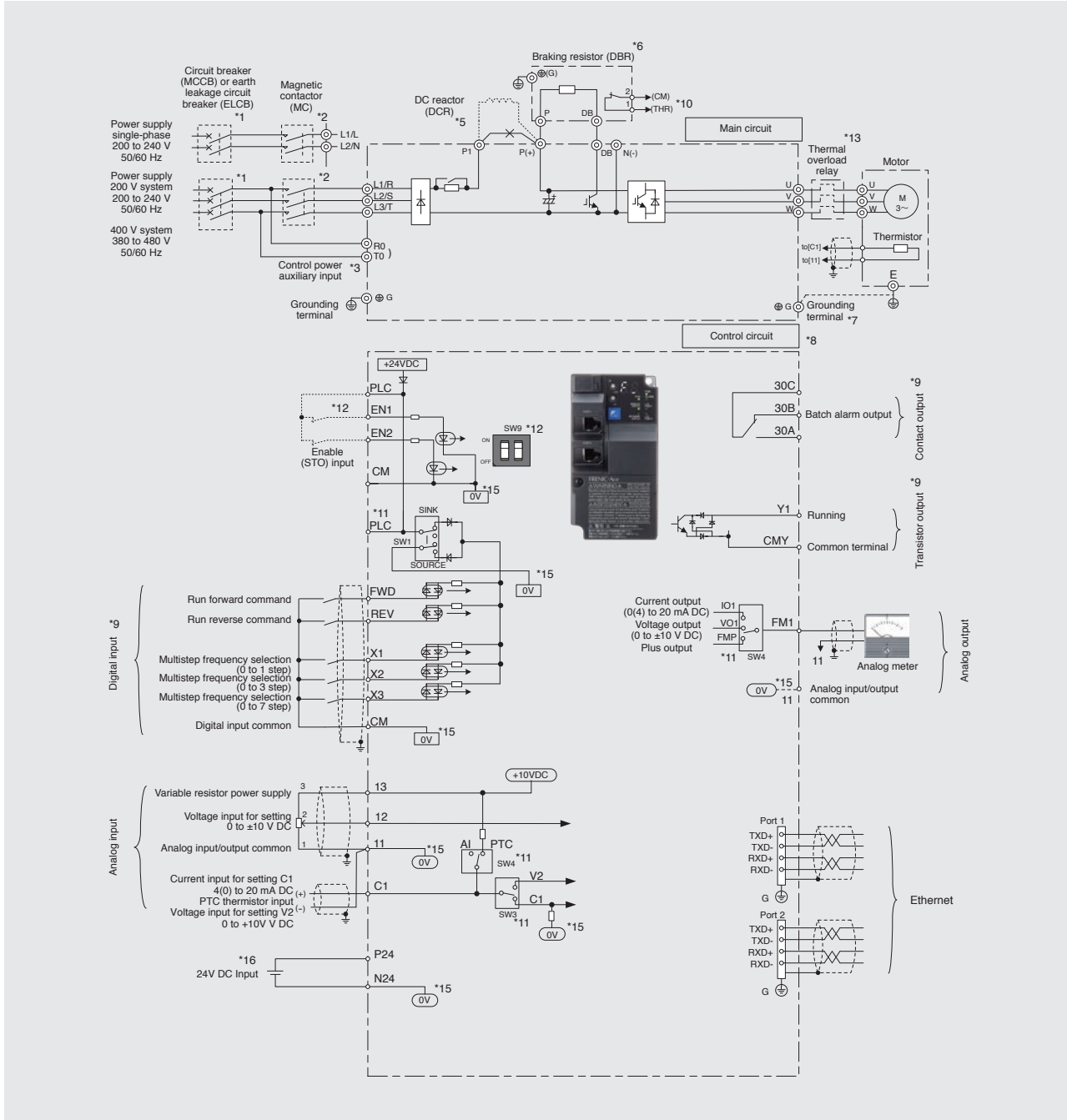

- *1 Install the molded case circuit breaker (MCCB) or earth leakage circuit breaker (ELCB) (with overcurrent protection function) recommended for each inverter on the inverter input side (primary side) to protect wiring. Do not use a circuit breaker that exceeds the recommended rated current.
- *2 An MCCB or ELCB is also used if isolating the inverter from the power supply, and therefore the magnetic contactor (MC) recommended for each inverter should be installed if required. Please note that if installing a coil such as an MC or solenoid near the inverter, connect a surge absorber in parallel.
- *3 If wishing to retain the integrated alarm signal issued if the protective function is triggered even when the inverter main power supply is cut off, or to constantly display the keypad, connect these terminals to the power supply. (on FRN008E3□-2G or higher / FRN005E3□-4G or higher) The inverter can be run even without inputting the power supply to these terminals.
- *5 Remove the shorting bar between the inverter main circuit terminals P1 and P(+) before connecting the DC reactor (DCR) (option). Use a DC reactor (DCR) when the capacity of the power supply transformer is 500 kVA or more and is 10 times or more the inverter rated capacity, or when there are "thyristor-driven" loads.
- *6 Inverters are equipped with a built-in braking transistor, allowing direct connection of braking resistors between P(+) and DB.
- *7 This terminal is used for grounding the motor. Connect if required.
- *8 Use twisted wire or shielded wire for control signal lines. Shielded wires are generally grounded, however, if subject to significant induction noise from outside, it may be possible to suppress the effect of the noise by connecting wires to [CM]. Isolate control signal lines from the main circuit wiring as best as possible, and do not run inside the same duct (a distance of 10 cm or greater is recommended.) If lines intersect, ensure that they do so almost perpendicularly to the main circuit wiring.
- *9 Each of the functions described for terminals [FWD] and [REV], terminals [X1] to [X3] (digital input), terminal [Y1] (transistor output), and terminal [30A/B/C] (contact output) indicate functions assigned by factory default.
- *11 These are the switches on control PCBs, and are used to specify settings for inverter operation. Refer to the User's Manual for details.
- *12 Safety function terminals [EN1] and [EN2] are disabled with SW9 (2-pole switch) on the control PCB by factory default. If using this terminal function, be sure to change the respective SW9 switches to the OFF position and connect.
- *13 The thermal overload relay is applicable as necessary. Make the circuit breakers (MCCB) or the magnetic contactors (MC) trip by the thermal relay auxiliary contacts (manual recovery).
- *15 $\overline{0V}$ and $\underline{0V}$ are separated and insulated.
- *16 By connecting a power supply to this terminal, Ethernet communication is possible even when the main power supply of the inverter is cut off. The inverter can be operated without inputting power to this terminal.

Features
Main application examples
Model variations
Type number nomenclature
Standard specifications
Common specifications
Terminal specifications
Basic wiring diagram
External dimensions
Keypad
Function codes
Options
Product warranty

External Dimensions

Basic type

Type FRN0001E3S-2G to FRN0006E3S-2G
FRN0001E3S-7G to FRN0006E3S-7G

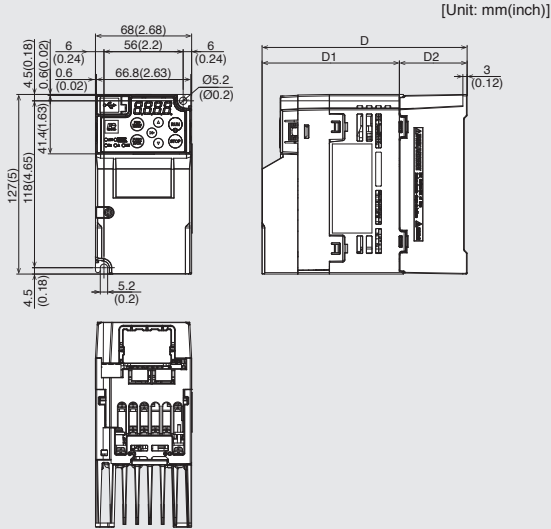

Power system	Inverter type (HHD)	Dimensions [mm (inch)]		
		D	D1	D2
Three-phase 200 V	FRN0001E3S-2G, FRN0002E3S-2G	98(3.85)	90(3.54)	8(0.31)
	FRN0004E3S-2G	113(4.45)	90(3.54)	23(0.9)
	FRN0006E3S-2G	145(5.71)	97(3.82)	48(1.89)
Single-phase 200 V	FRN0001E3S-7G, FRN0002E3S-7G	98(3.85)	90(3.54)	8(0.31)
	FRN0004E3S-7G	120(4.72)	97(3.82)	23(0.9)
	FRN0006E3S-7G	165(6.5)	117(4.61)	48(1.89)

Type FRN0010E3S-2G, FRN0012E3S-2G
FRN0002E3S-4G to FRN0007E3S-4G, FRN0010E3S-7G

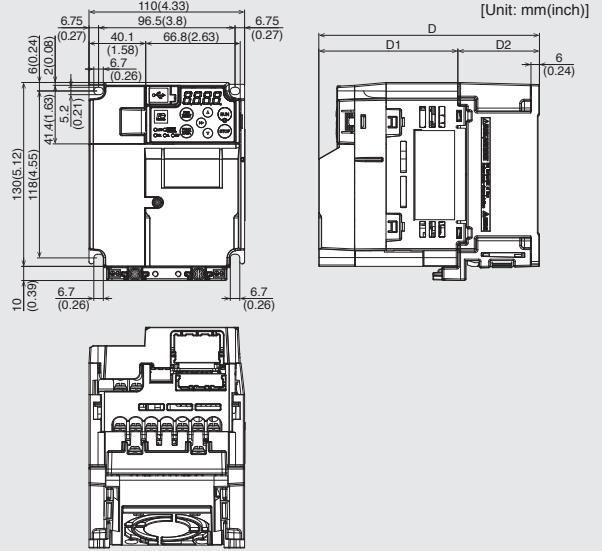

Power system	Inverter type (HHD)	Dimensions [mm (inch)]		
		D	D1	D2
Three-phase 200 V	FRN0010E3S-2G, FRN0012E3S-2G	156(6.14)	98(3.85)	58(2.27)
Three-phase 400 V	FRN0002E3S-4G	132(5.2)	98(3.85)	34(1.33)
	FRN0004E3S-4G to FRN0007E3S-4G	156(6.14)	98(3.85)	58(2.27)
Single-phase 200 V	FRN0010E3S-7G	166(6.54)	108(4.25)	58(2.27)

Type FRN0020E3S-2G
FRN0012E3S-4G, FRN0012E3S-7G

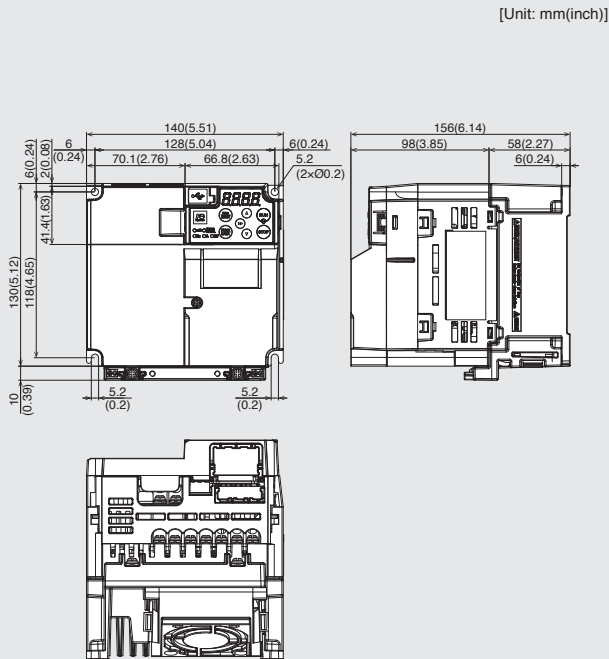

Type FRN0030E3S-2G, FRN0040E3S-2G
FRN0022E3S-4G, FRN0029E3S-4G

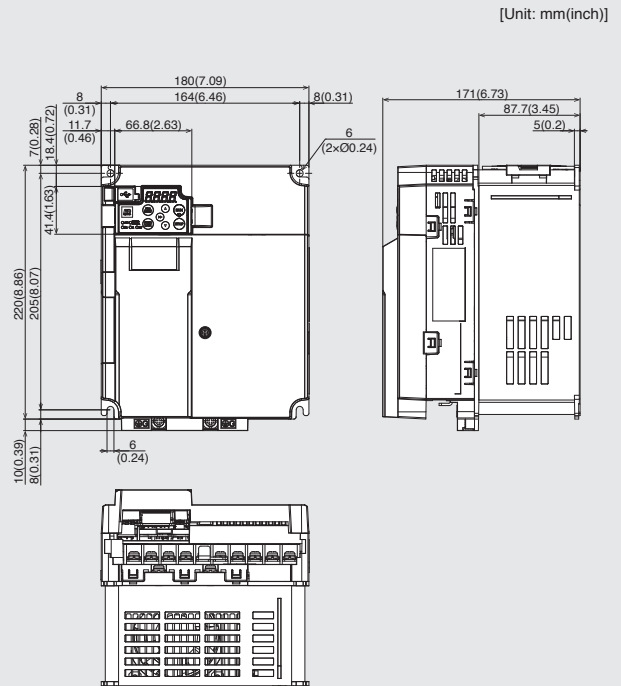

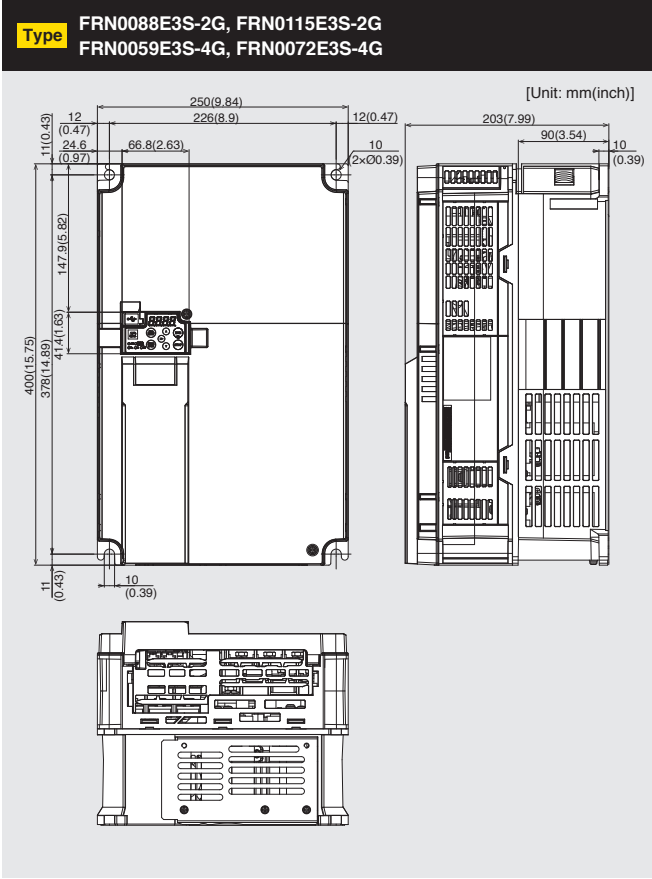
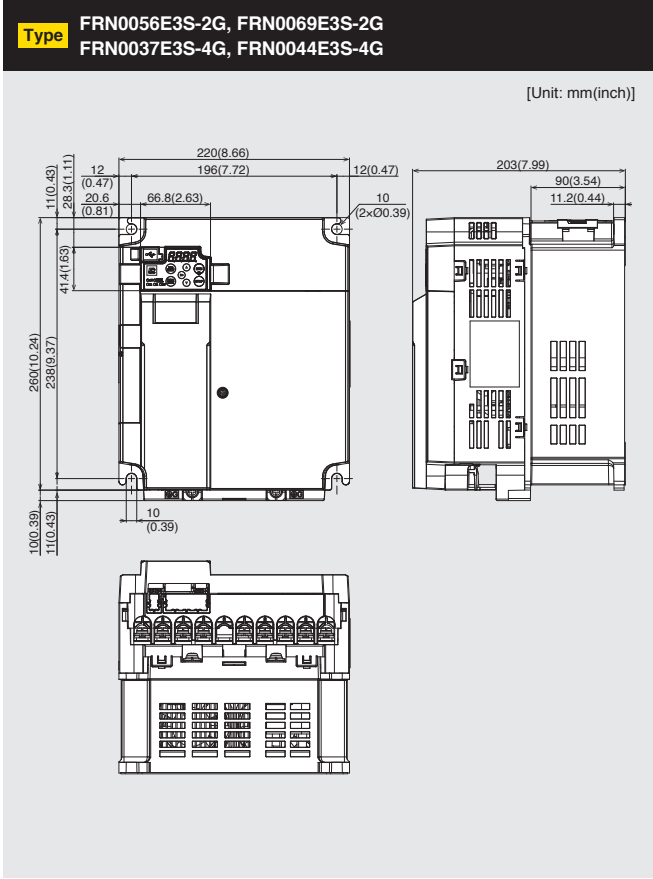

Product warranty

Options

Function codes

Keypad

External dimensions

Basic wiring diagram

Terminal specifications

Common specifications

Standard specifications

Type number nomenclature

Model variations

Main application examples

Features

External Dimensions

Ethernet built-in type

Type FRN0001E3N-2G to FRN0006E3N-2G
FRN0001E3N-7G to FRN0006E3N-7G

[Unit: mm(inch)]

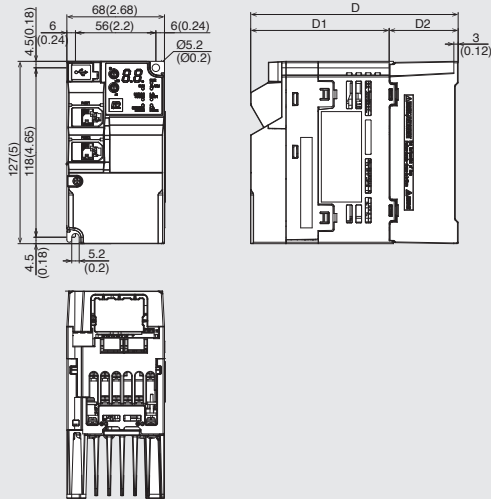

Power system	Inverter type (HHD)	Dimensions [mm (inch)]		
		D	D1	D2
Three-phase 200 V	FRN0001E3N-2G, FRN0002E3N-2G	98(3.85)	90(3.54)	8(0.31)
	FRN0004E3N-2G	113(4.45)	90(3.54)	23(0.9)
	FRN0006E3N-2G	145(5.71)	97(3.82)	48(1.89)
Single-phase 200 V	FRN0001E3N-7G, FRN0002E3N-7G	98(3.85)	90(3.54)	8(0.31)
	FRN0004E3N-7G	120(4.72)	97(3.82)	23(0.9)
	FRN0006E3N-7G	165(6.5)	117(4.61)	48(1.89)

Type FRN0010E3N-2G, FRN0012E3N-2G
FRN0002E3N-4G to FRN0007E3N-4G, FRN0010E3N-7G

[Unit: mm(inch)]

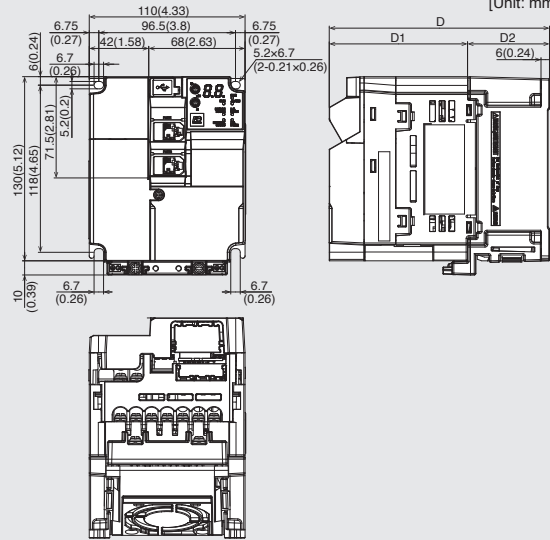

Power system	Inverter type (HHD)	Dimensions [mm (inch)]		
		D	D1	D2
Three-phase 200 V	FRN0010E3N-2G, FRN0012E3N-2G	156(6.14)	98(3.85)	58(2.27)
Three-phase 400 V	FRN0002E3N-4G	132(5.2)	98(3.85)	34(1.33)
	FRN0004E3N-4G to FRN0007E3N-4G	156(6.14)	98(3.85)	58(2.27)
Single-phase 200 V	FRN0010E3N-7G	166(6.54)	108(4.25)	58(2.27)

Type FRN0020E3N-2G
FRN0012E3N-4G, FRN0012E3N-7G

[Unit: mm(inch)]

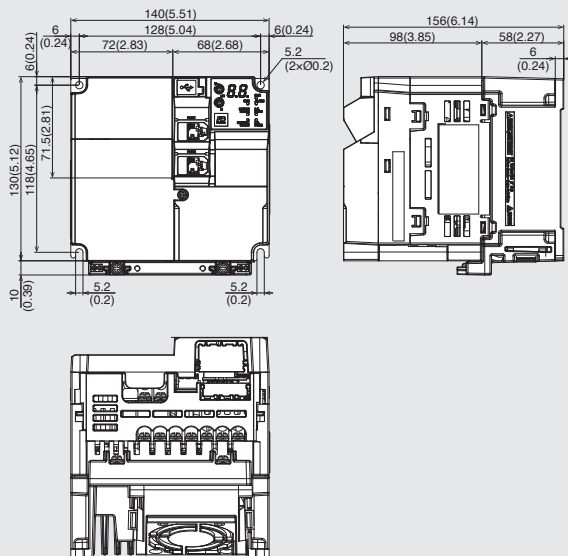

Type FRN0030E3N-2G, FRN0040E3N-2G
FRN0022E3N-4G, FRN0029E3N-4G

[Unit: mm(inch)]

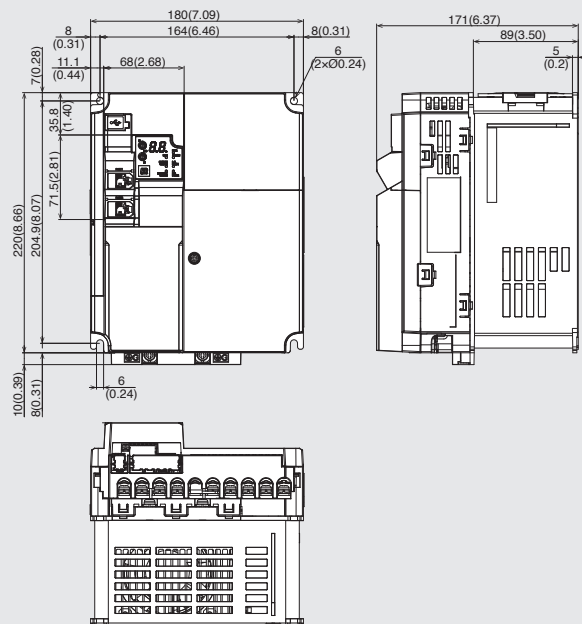

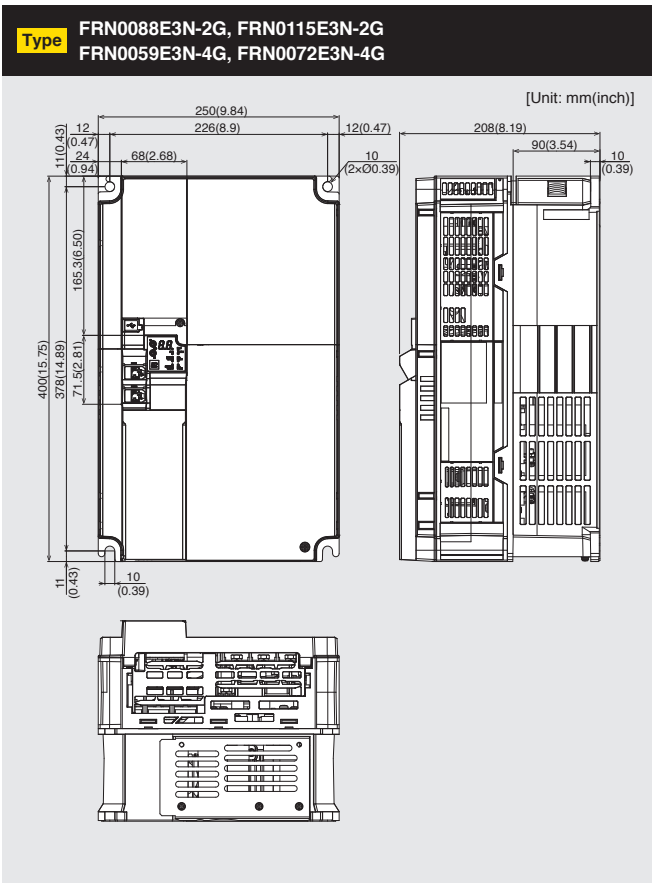
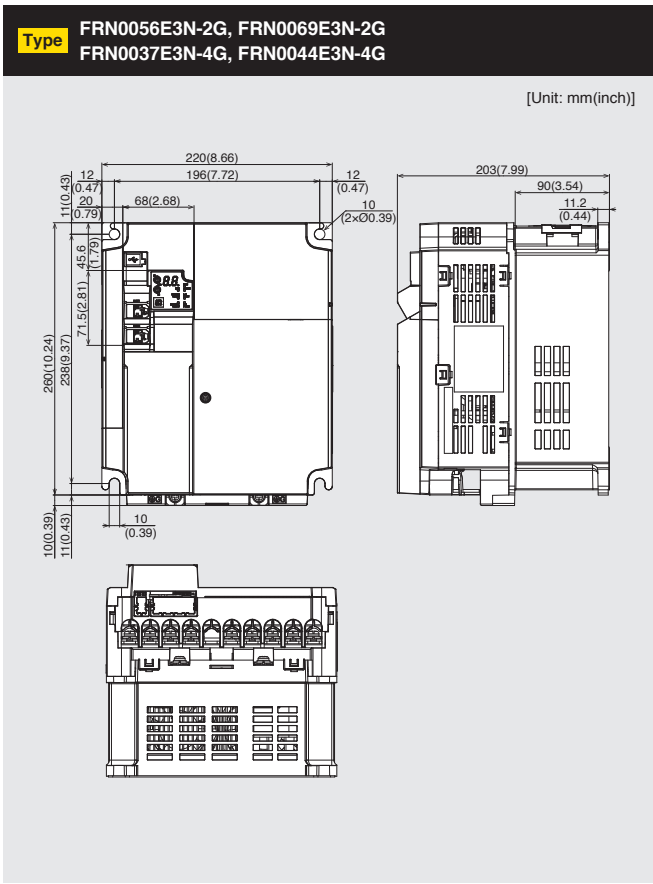

Product warranty

Options

Function codes

Keypad

External dimensions

Basic wiring diagram

Terminal specifications

Common specifications

Standard specifications

Type number nomenclature

Model variations

Main application examples

Features

External Dimensions

EMC Filter built-in type

Type FRN0001E3E-7G to FRN0006E3E-7G

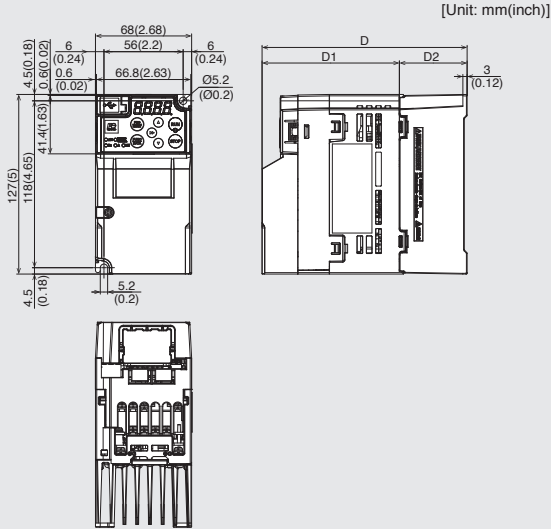

Power system	Inverter type (HHD)	Dimensions [mm (inch)]		
		D	D1	D2
Single-phase 200 V	FRN0001E3E-7G, FRN0002E3E-7G	125(4.92)	117(4.61)	8(0.31)
	FRN0003E3E-7G	140(5.51)	117(4.61)	23(0.9)

Type FRN0002E3E-4G, FRN0004E3E-4G

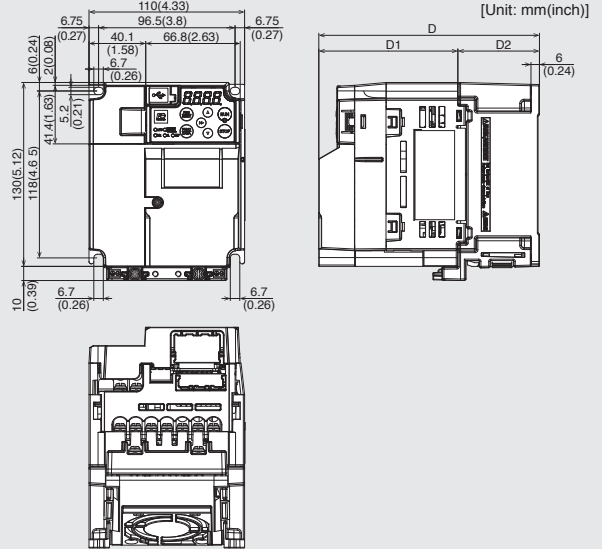

Power system	Inverter type (HHD)	Dimensions [mm (inch)]		
		D	D1	D2
Three-phase 400 V	FRN0002E3E-4G	175(6.89)	141(5.56)	34(1.33)
	FRN0004E3E-4G	199(7.83)	141(5.56)	58(2.29)

Type FRN0005E3E-7G

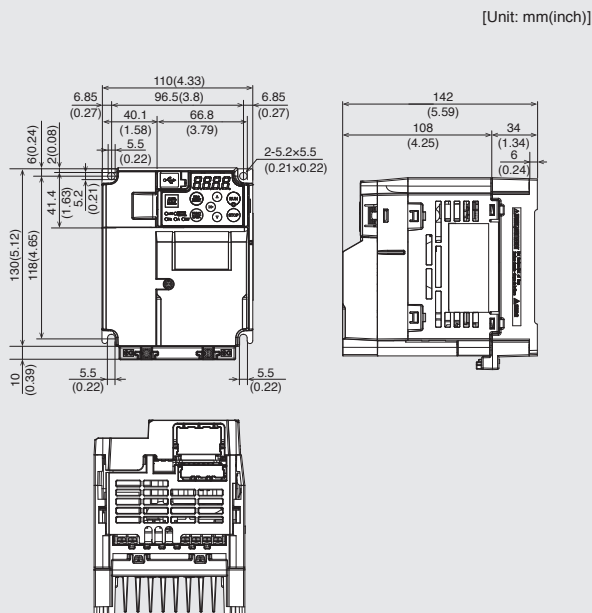

Type FRN0006E3E-4G, FRN0007E3E-4G, FRN00012E3E-4G, FRN0008E3E-7G, FRN0011E3E-7G

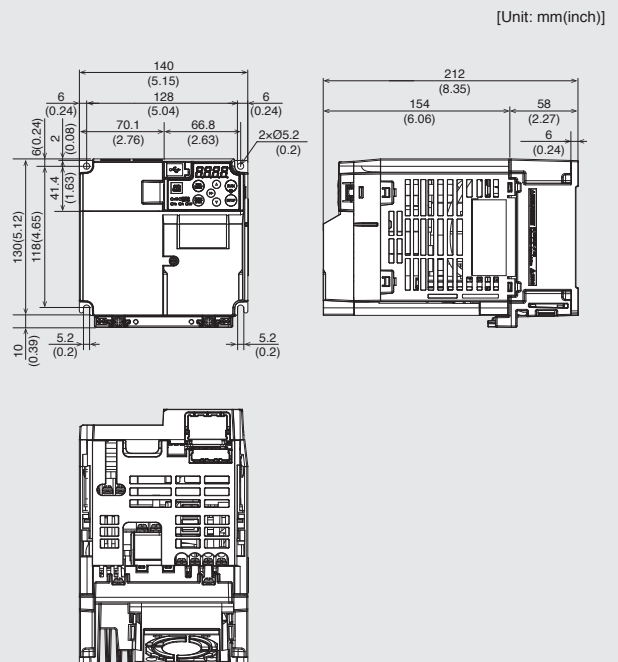

EMC Filter built-in type

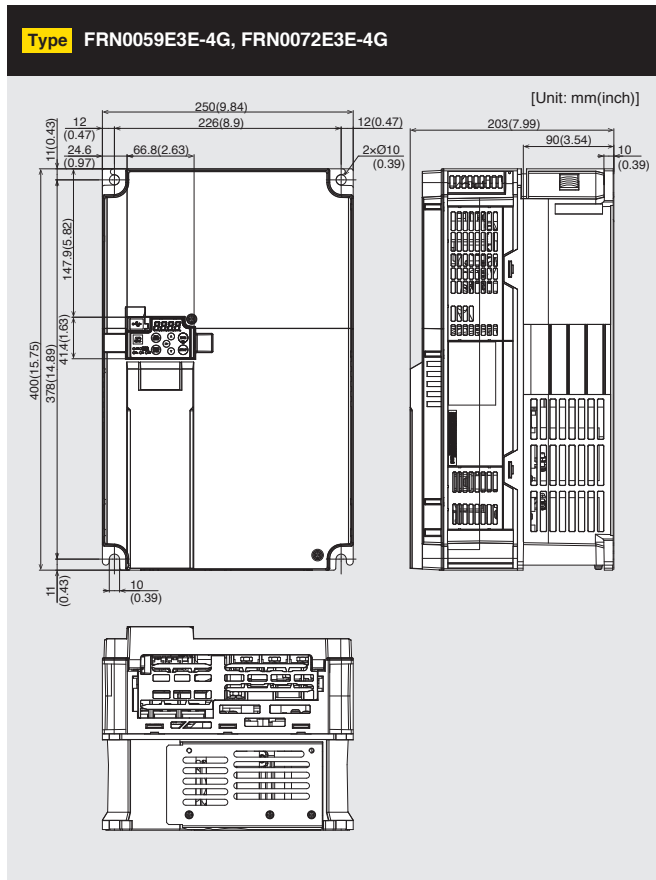
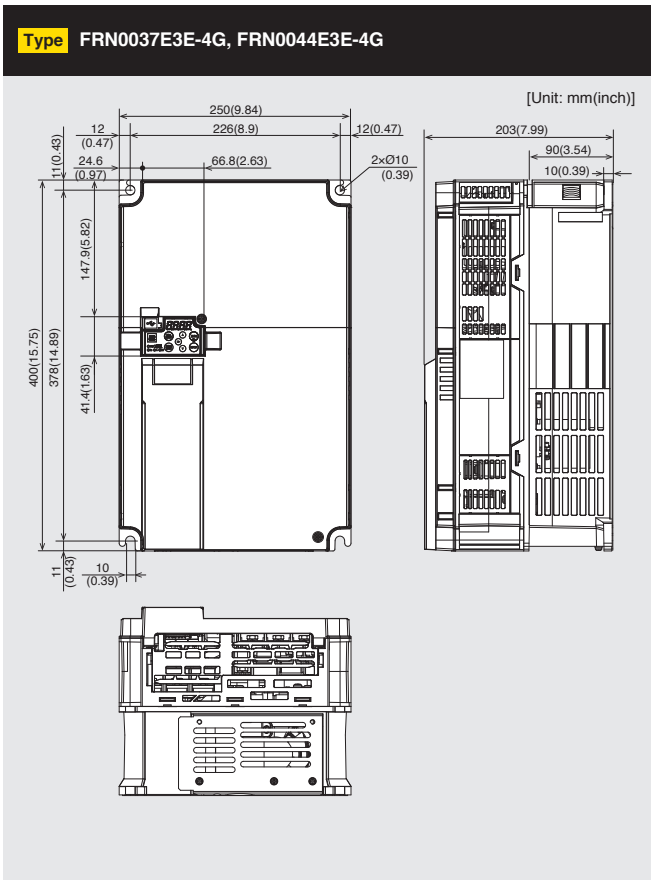

Features

Main application examples

Model variations

Type number nomenclature

Standard specifications

Common specifications

Terminal specifications

Basic wiring diagram

External dimensions

Keypad

Function codes

Options

Product warranty

External Dimensions

Keypad

Standard (without USB) Type: TP-M3

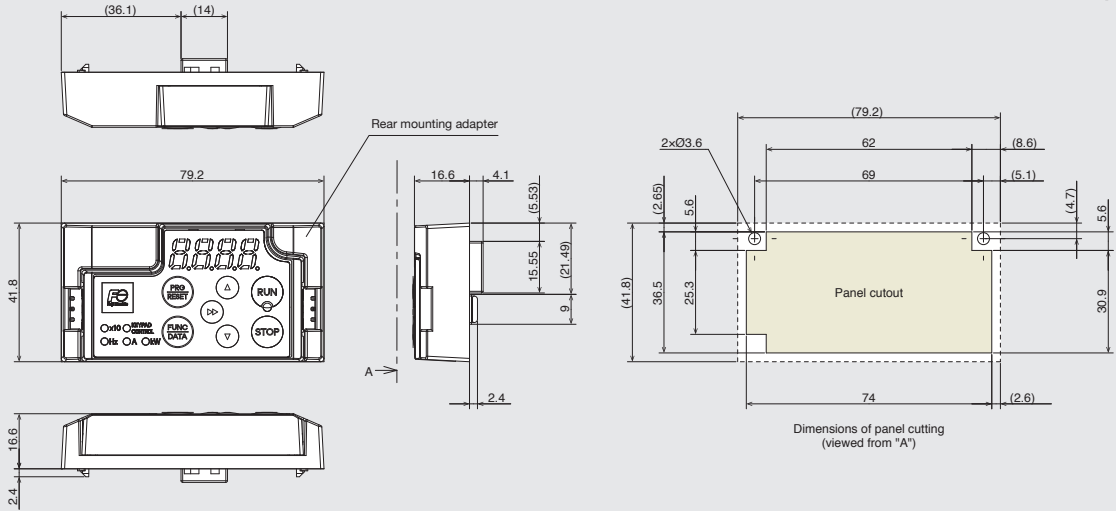

Note) The figure shows the optional rear mounting adapter (CBAD-CP). Please check when remotely operating or installing the panel. TP-M3 is a standard accessory. Please note that this accessory cannot be purchased as an optional item.

For remote keypad Type: TP-E2 Option

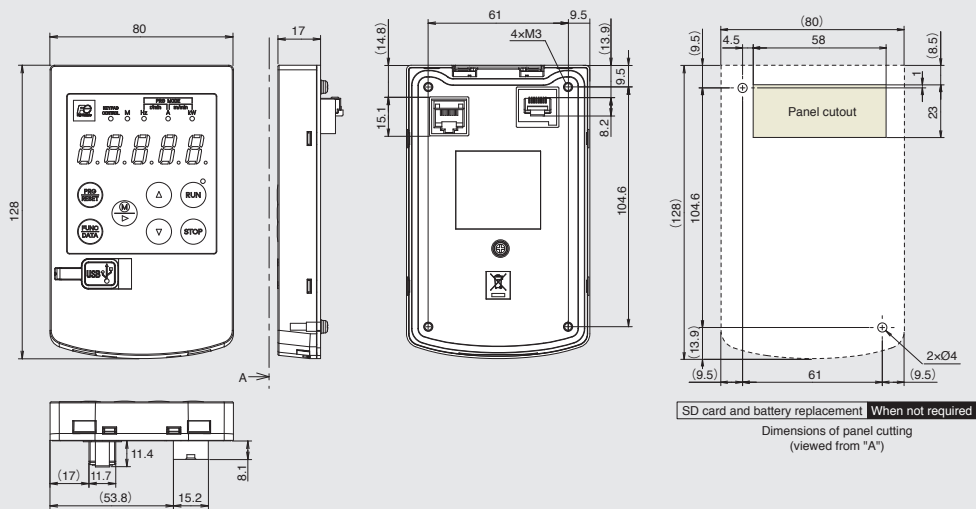

Note) This figure shows the installation of the optional rear mounting adapter (CBAD-CP). Please check the figure when performing remote control or during panel installation. The CBAD-CP keypad relay adapter is required to remotely connect the keypad to the FRENIC-Ace (E3).

Multi-function keypad (with USB) Type: TP-A2SW Option

[Unit: mm]

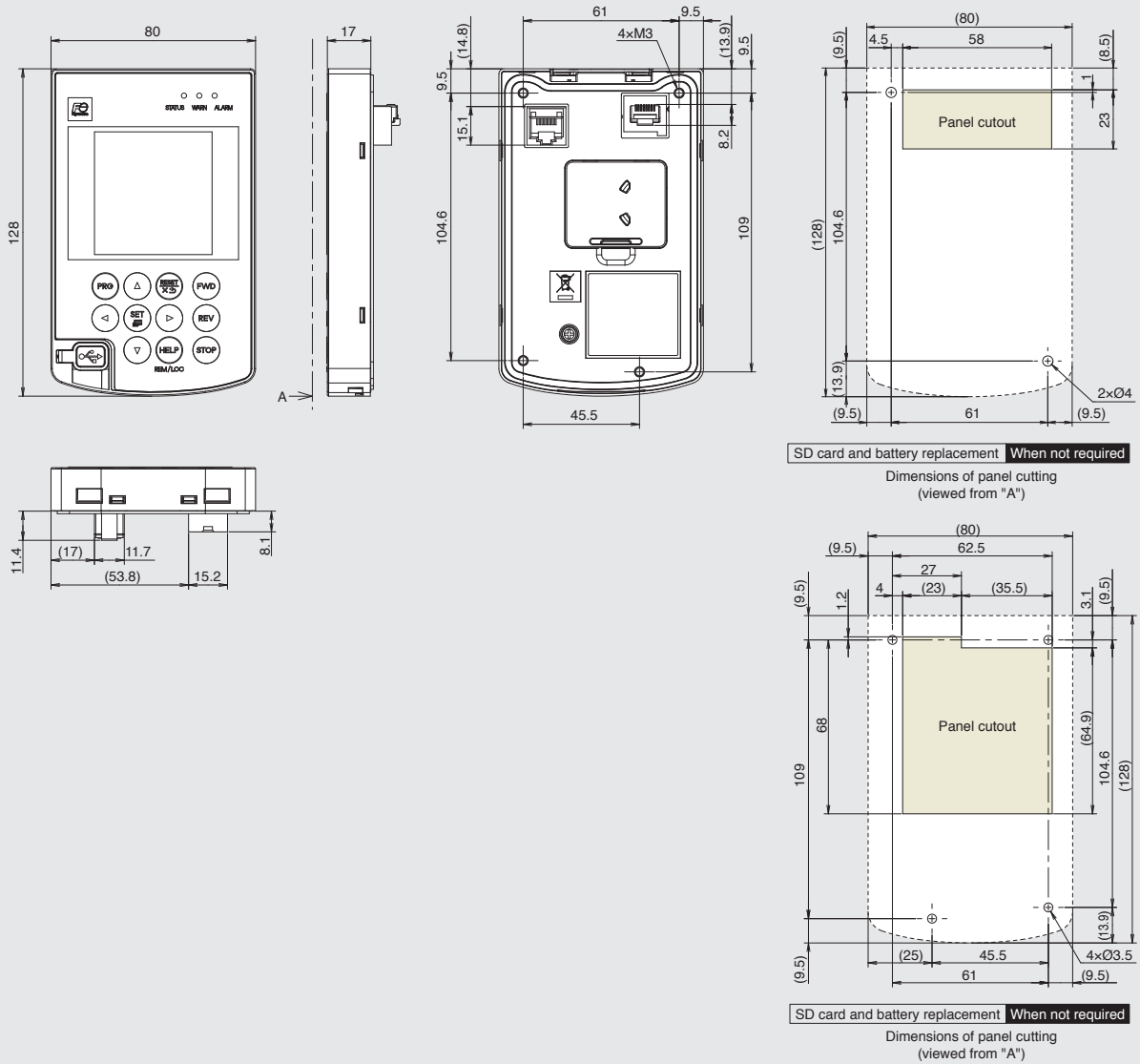

Note) This figure shows the installation of the optional rear mounting adapter (CBAD-CP). Please check the figure when performing remote control or during panel installation.
 The CBAD-CP keypad relay adapter is required to remotely connect the keypad to the FRENIC-Ace (E3).

Keypad Functions

Use the keypad to start and stop the inverter, display various data, set function code data, check I/O, and display maintenance and alarm information.



Overview of operation and functionality

Item	Display and keys	Overview of functionality
Data display		<p>This is a 4-digit, 7-segment LED monitor. It displays the following information for each operation mode.</p> <ul style="list-style-type: none"> ■ Operation mode : Operation information (output frequency, output current, output voltage, etc.) Switches to minor failure display when a minor failure occurs. ■ Program mode : Menu, function code, function code data, etc. ■ Alarm mode : Alarm code indicating the cause of the protection function's activation.
Key operation		<p>Switches the operation mode.</p> <ul style="list-style-type: none"> ■ Operation mode : Pressing this key will switch it to program mode. ■ Program mode : Pressing this key will switch it to operation mode. ■ Alarm mode : After clearing the alarm cause, pressing this key will switch it to the operation mode deactivated by the alarm.
		<p>Performs the following operations:</p> <ul style="list-style-type: none"> ■ Operation mode : Switches the operation state monitoring items (output frequency, output current, output voltage, etc.). ■ Program mode : Displays function code or establishes the data. ■ Alarm mode : Switches the display of the alarm detailed information.
		Starts the motor operation. (When the keypad is being operated)
		Stops the motor operation. (When the keypad is being operated)
		Used to select the setting items displayed on the LED monitor or change the function code data.
		<ul style="list-style-type: none"> ■ Operation mode : The functionality assigned by function code E70 is available. Press and hold for one second to turn the functionality ON or OFF. It is OFF by default when the power is turned on. ■ Program mode <ul style="list-style-type: none"> During menu display : Proceeds to the next menu number. During function code display : Advances the display number in steps of 10. During numerical setting : Moves the cursor digit to the right. ■ Alarm mode : Advances the alarm detailed information number in steps of 10.
LED display	RUN (Green)	Lights up when the " " key is pressed or when operated by issuing the "FWD" or "REV" signal or communication commands.
	KEYPAD CONTROL (Green)	Lights up when the key on the keypad is enabled as an operation command. However, in program mode or alarm mode, no operation is possible even if this LED is lit. It blinks every second in local mode.
	Unit LEDs (three red LEDs)	Hz, A, kW, r/min, m/min: Displays the unit when monitoring the operating status in operation mode via a combination of three LEDs. PRG.MODE: Two LEDs on the left and right will light up when you transition to program mode. (● Hz ● A ● kW)
	x10 LED (Red)	If the data to be displayed exceeds 9999, the x10 LED will light up and the actual data will be represented by the "Displayed data x10". E.g.: When the data is 12,345, the LED monitor will display " <i>1234</i> " and the x10 LED will light up at the same time, meaning 1,234 x10 = 12,340.

Keypad Operation

» LED monitor

In Running mode, the LED monitor displays running status information (output frequency, current or voltage); in Programming mode, it displays menus, function codes and their data; and in Alarm mode, it displays an alarm code which identifies the alarm factor that has activated the protective function.

If one of LED4 through LED1 is blinking, it means that the cursor is at this digit, allowing you to change it.

In addition, the dot indicating the decimal point in LED1 will blink to indicate that the currently displayed value is the PID command value, thereby distinguishing it from the frequency display.

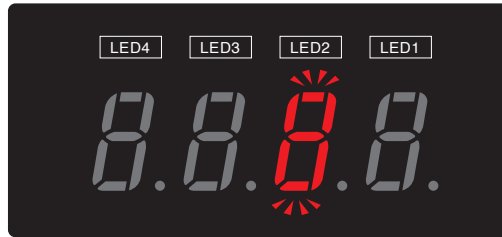

7-segment LED monitor (LED2 is blinking)

■ 7-segment LED monitor display

Character	7-segment	Character	7-segment	Character	7-segment	Character	7-segment
0	0	9	9	I *	I or I	R	r
1	1	A	A	J	J	S	S
2	2	B	b	K	P	T*	f or t
3	3	C*	C or c	L	L	U*	U or u
4	4	D	d	M	M	V*	U or u
5	5	E	E	N	n	W	W
6	6	F	F	O*	O or o	X	X
7	7	G*	G or g	P	P	Y	Y
8	8	H*	H or h	Q	Q	Z	Z
Special characters and symbols (numbers with decimal point, minus and underscore)							
-	-	-	-	[[]]
%	% or %						

*: Upper case and lower case characters are used based on the displayed content.

Keypad Operation

Overview of Operation Modes

FRENIC-Ace is equipped with the following three operation modes.

Operation mode	Description
Running Mode	<ul style="list-style-type: none"> When powered ON, the inverter automatically enters this mode. This mode allows you to specify the reference frequency, PID command value and etc., and run/stop the motor with the RUN / STOP keys. The running status can also be monitored in real time. Changes to the status display when not in the normal running status. Changes to the light alarm display when a light alarm occurs.
Programming Mode	This mode allows you to configure function code data and check a variety of information relating to the inverter status and maintenance.
Alarm Mode	<p>If an alarm condition arises, the inverter automatically enters Alarm mode in which you can view the corresponding alarm code* and its related information on the LED monitor.</p> <p>* Alarm code: Indicates the cause of the alarm condition.</p>

Status transition between operation modes

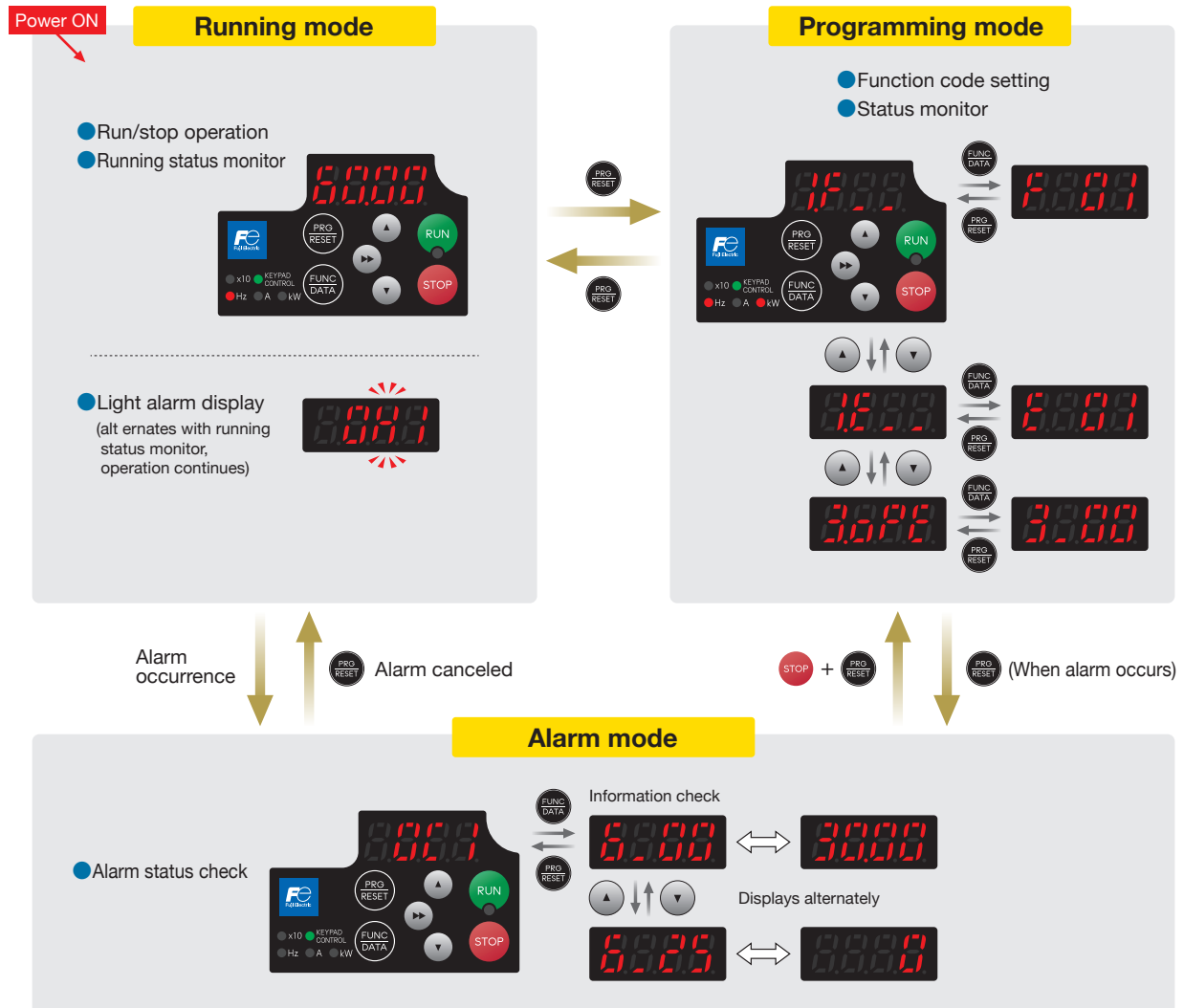

Tip

Simultaneous keying

Simultaneous keying means pressing two keys at the same time.

The simultaneous keying operation is expressed by a "+" letter between the keys throughout this manual.

For example, the expression "**STOP** + **PRG/RESET** keys" stands for pressing the **STOP** key with the **PRG/RESET** key held down.

Running Mode

Operating State Monitor

In running mode, the items in Table 3.3-1 below can be monitored. The monitor items set with function code E43 are displayed immediately after turning the power on. Press the  key to switch between monitor items.

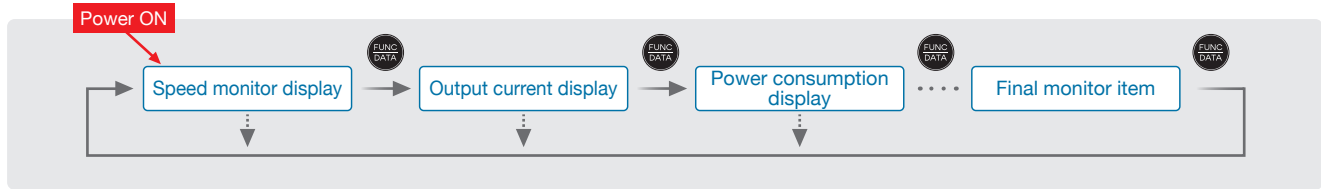

Tip Press and hold the  key to return to the initial display (monitor item set with E43).

Monitor items

●:ON ●:OFF

Monitor item	example	LED indication	Unit	Meaning of displayed value	Data for E43
Speed monitor	Function code E48 specifies what to be displayed on the LED monitor and LED indicators.				0
Output frequency 1 (before slip compensation)	50.00	●Hz ●A ●kW	Hz	Frequency actually being output	(E48=0)
Output frequency 2 (after slip compensation)	50.00	●Hz ●A ●kW	Hz	Frequency actually being output	(E48=1)
Frequency specified by frequency command when alarm occurred	50.00	●Hz ●A ●kW	Hz	Indicated value = Reference frequency (Hz)	(E48=2)
Motor speed	1500	●Hz ●A ●kW	min ⁻¹	Indicated value = Output frequency (Hz) × $\frac{120}{P01}$	(E48=3)
Load shaft speed	300.0	●Hz ●A ●kW	min ⁻¹	Indicated value = Output frequency (Hz) × E50	(E48=4)
Line speed	300.0	●Hz ●A ●kW	m/min	Indicated value = Output frequency (Hz) × E50	(E48=5)
Constant feeding rate time	50	●Hz ●A ●kW	min	Indicated value = $\frac{E50}{\text{Output frequency (Hz)} \times E39}$	(E48=6)
Speed (%)	50.0	●Hz ●A ●kW	%	Indicated value = $\frac{\text{Output frequency (Hz)}}{\text{Max. frequency}} \times 100$	(E48=7)
Output current when alarm occurred.	12.34	●Hz ●A ●kW	A	Current output from the inverter in RMS	3
Power consumption	10.25	●Hz ●A ●kW	kW	Input power to the inverter	9
Calculated torque *1	50	●Hz ●A ●kW	%	Motor output torque in % (Calculated value)	8
Output voltage *2	200V	●Hz ●A ●kW	V	Output voltage (RMS) of the inverter	4
Motor output *3	9.85	●Hz ●A ●kW	kW	Motor output (kW)	16
Load factor *4	50%	●Hz ●A ●kW	%	Load factor of the motor in % as the rated output being at 100%	15
PID output *5, *6	10.00	●Hz ●A ●kW	-	PID command/feedback amount converted to a physical quantity of the object to be controlled	10
PID feedback value*5,*7	9.00	●Hz ●A ●kW	-	Refer to function codes J106 and J107 for details.	12
PID deviation*5, *7	1.00	●Hz ●A ●kW	-	PID command value and PID feedback value deviation converted into physical quantities of the object to be controlled	29
PID output *5, *6	100.0	●Hz ●A ●kW	%	PID output in % as the maximum frequency (F03) being at 100%	14
Timer *10	50	●Hz ●A ●kW	s	Remaining time for timer operation	13
Analog input monitor *8	82.00	●Hz ●A ●kW	-	An analog input to the inverter in a format suitable for a desired scale. Refer to the following function codes. Terminal [12]: C59, C60 Terminal [C1] (C1 function): C65, C66 Terminal [C1] (V2 function): C71, C72	17
Command position*11	765 4321	●Hz ●A ●kW	-	Alternate display of 4 higher order digits (with sign) and 4 lower order digits	21
Positioning deviation*11	765 4321	●Hz ●A ●kW	-	Alternate display of 4 higher order digits (with sign) and 4 lower order digits	22

*1 Calculated torque 100% is equal to the motor rated torque. For the calculation formula of the motor rated torque, refer to E.2 "Calculated formula" (1) in Appendix E "Conversion from SI Units."
 *2 If displaying the output voltage, is displayed as the last digit on the LED monitor to denote the unit for V (volts). *3 When the LED monitor displays the motor output, the unit LED indicator "kW" blinks.
 *4 When the LED monitor displays the load factor, the 7-segment letter in the lowest digit stands for "%". *5 These PID related items appear only under the PID control specified by function code J01 (= 1, 2 or 3).
 *6 When the LED monitor displays a PID command or its output amount, the dot (decimal point) attached to the lowest digit of the 7-segment letter blinks.
 *7 When the LED monitor displays a PID feedback amount, the dot (decimal point) attached to the lowest digit of the 7-segment letter lights.
 *8 The analog input monitor appears only when the analog input monitor function is assigned to one of the analog input terminals by one of function codes E61 to E63 (= 20). Specify the unit with C58, C64 and C70.
 *9 Displays 0 (zero) under V/f control. *10 Displays (function code C21 = 3) only if performing timer operation. *11 Displays when the position control function is enabled.

Keypad Operation

Monitor items

●:ON ○:OFF

Monitor item	example	LED indication	Unit	Meaning of displayed value	Data for E43
Stop target position*11	765 4321.	●Hz ●A ●kW	-	Alternate display of 4 higher order digits (with sign) and 4 lower order digits (with sign) for stop target position with user value	28
Torque current *9	48	●Hz ●A ●kW	%	Torque current command value or calculated torque current	23
Magnetic flux command *9	50	●Hz ●A ●kW	%	Magnetic flux command value	24
Input watt-hour	100.0	●Hz ●A ●kW	kWh	Indicated value = $\frac{\text{Input watt-hour (kWh)}}{100}$	25
Torque bias	25	●Hz ●A ●kW	%	Torque bias value display	30
Estimated inertia acceleration/ deceleration time conversion value	1.234	●Hz ●A ●kW	s	Display of estimated inertia result in logic acceleration/deceleration time	31
Customizable logic output*12	82.00	●Hz ●A ●kW	-	Display of output content for specific customizable logic step	32

*9 Displays 0 (zero) under V/f control.

*11 Displays when the position control function is enabled.

*12 Displays only if U00 = 1 and U98 0.



Tip

The monitoring signals for the monitor items such as keypad output frequency and output current can be filtered with function code E42 (LED display filter). If the display varies unstably so as to be hard to read due to load fluctuation or other causes, increase this filter time constant. (Function code E42)

Programming Mode

The Programming mode provides you with the following functions--setting and checking function code data, monitoring maintenance information and checking input/output (I/O) signal status. The functions can be easily selected with the menu-driven system. Table 3.4-1 below lists menus available in Programming mode. The leftmost digit (numerals) of each letter string on the LED monitor indicates the corresponding menu number and the remaining digits indicate the menu contents.

When the inverter enters Programming mode from the second time on, the menu selected last in Programming mode will be displayed.

Menus available in programming mode

Menu #	Menu	LED monitor indication	Main function
1	"Data Setting"	1.F..	F codes (Basic functions)
		1.E..	E codes (Extension terminal functions)
		1.C..	C codes (Control functions)
		~ (Omitted) ~	
		1.P..	k codes (optional functions)
2	"Data Checking"	2.rEP	Displays only function codes that have been changed from their factory defaults. The function code data can be referenced and changed.
3	Run monitor	3.oPE	Displays the running information required for maintenance or test runs.
4	I/O check	4.i.o	Displays external interface information.
5	"Maintenance Information"	5.cHE	Displays maintenance information including cumulative run time.
6	Alarm Information	6.aL	Alarm codes for the past four alarms can be displayed, and operating information at the time each alarm occurred can be referenced.
8	Destination setting	8.dEst	Sets the region (overseas) in which the product is used. This is not used for machines for use in Japan.
9	Communication monitor	9.S 9.Addr 9.aRtR	Codes communicated back and forth between the host device can be monitored, and communication commands can be entered. Refer to the "RS-485 Communication User's Manual" for details.
0	Favorites	0.FnC	Only function codes selected by users can be referenced or changed.



Tip

Enter Programming mode at the keypad to display the menu. Change the menu with the ▲ and ▼ keys, and select the desired menu item with the key. Once the entire menu has been cycled through, the display returns to the first menu item. Press the key to proceed to the next menu number.

Programming Mode

Reading alarm information **Alarm Information 6.AL**

Menu number 6 “Alarm Information: **6.AL**” shows which protective function performed for the past 10 alarms with an alarm code. Further, it also displays alarm information that indicates the status of the inverter when the alarm occurred.

“Alarm Information” menu transition

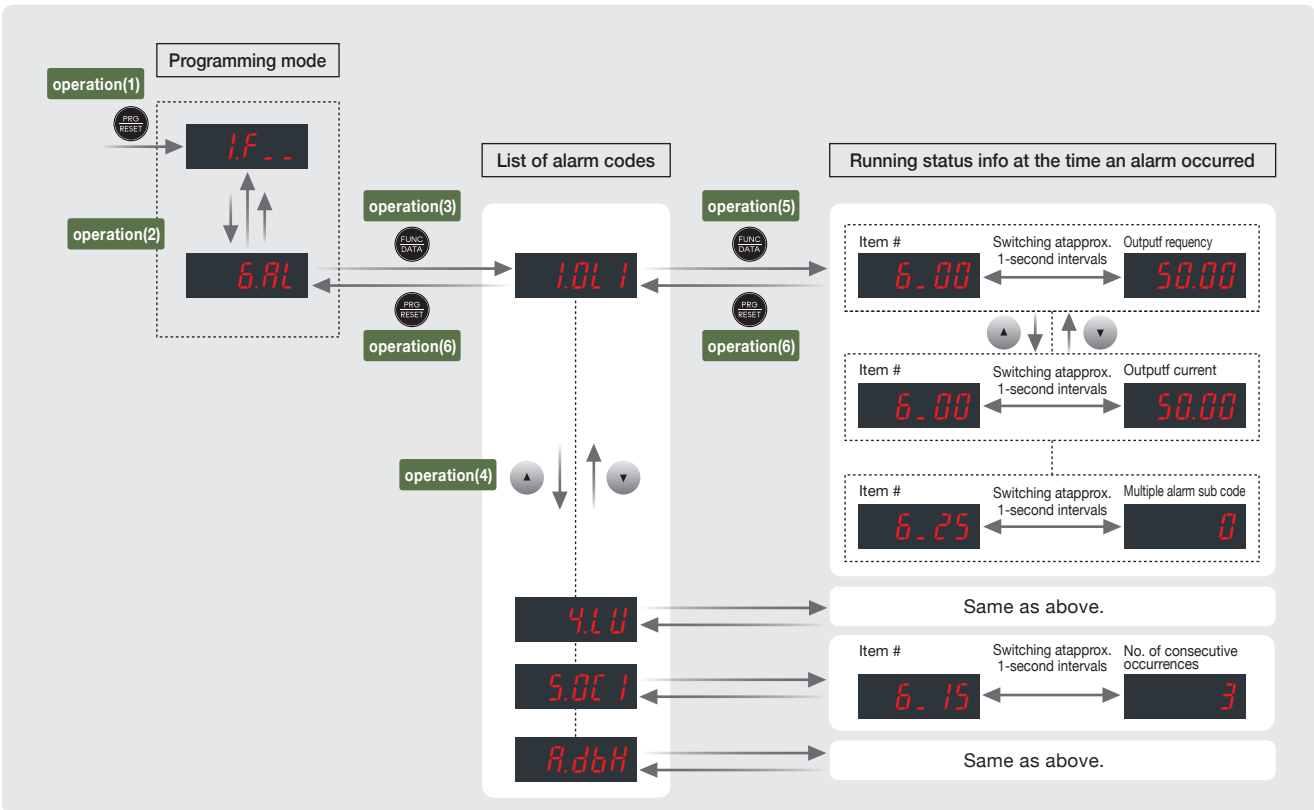

Basic key operation

- operation(1)** Turn the inverter ON. It automatically enters Running mode in which you press the **PRG. RESET** key to switch to Programming mode. The function selection menu appears.

- operation(2)** Use the **▲** or **▼** key to display “Alarm Information” (**6.AL**). Press the **▶▶** key to skip in menu number units.

- operation(3)** Press the **FUNC. DATA** key to proceed to the list of alarm codes (e.g., **1.OL 1**). In the list of alarm codes, the alarm information for the last 4 alarms is saved as an alarm history.

- operation(4)** Each time the **▲** or **▼** key is pressed, the last 4 alarms are displayed beginning with the most recent one in the order “1”, “2”, “3”, “4”. By pressing the **▶▶** key, the display returns to the latest alarm history.

- operation(5)** Press the **FUNC. DATA** key with an alarm code being displayed. The monitor number (e.g. **6.00**) and the inverter status information (e.g. Output frequency) at the time of the alarm occurrence alternately appear at approx. 1-second intervals. Pressing the **▲** / **▼** keys displays other monitor numbers (e.g., **6.01**) and the status information (e.g., Output current) for that alarm code. By pressing the **FUNC. DATA** key at this time, the display can be switched between the monitor number and symbol.

- operation(6)** Press the **PRG. RESET** key to return to the list of alarm codes. Press the **PRG. RESET** key again to return to the menu.

Keypad Operation

“Alarm Information” display content

Monitor No.	Displayed content	Description
6.00	Output frequency	Output frequency before slip compensation when alarm occurred
6.01	Output current	Output current when alarm occurred. Unit: A (amperes)
6.02	Output voltage	Output voltage when alarm occurred Unit: V (volts)
6.03	Calculated motor output torque	Calculated motor output torque when alarm occurred
6.04	Frequency specified by frequency command	Frequency specified by frequency command when alarm occurred
6.05	Rotation direction	Displays the current rotation direction when alarm occurred. F: forward, r reverse, - - - -: stop
6.06	Running status	Running status in 4-digit hexadecimal format
6.07	Cumulative run time	Displays the cumulative main power supply up time of the inverter. Measurement range: 0 to 65,535 hours Display: The cumulative operating hours is displayed alternately in the upper two digits and the lower three digits. Examples: 0 ⇔ 535h (535 hours) 65 ⇔ 535h (65,535 hours) When the last three digits are displayed, h (hours) will be displayed at the end. If it exceeds 65,535 hours, it will return to 0 and reaccumulate.
6.08	Number of startups	It accumulates and displays the number of times the motor has been operated (the number of times the inverter's operation command was turned on). Measurement range: 0 to 65,535 times Display: 0 to 9999 When the number of times exceeds 1,000, the x10 LED will light up and display the value “, number of times ÷ 10”. If it exceeds 65,535 times, it will return to 0 and reaccumulate.
6.09	DC link bus voltage	Displays the DC link bus voltage of the inverter main circuit. Unit: V (volts)
6.10	Temperature inside the inverter	Displays the temperature of the inverter heat sink when alarm occurred. Unit: °C
6.11	Max. temperature of heat sink	Displays the temperature of the inverter heat sink when alarm occurred. Unit: °C
6.12	Terminal I/O signal status (displayed with ON/OFF of LED segments)	Displays I/O signal status.
6.13	Terminal input signal status (in hexadecimal)	
6.14	Terminal output signal status (in hexadecimal)	
6.15	No. of consecutive occurrences	Shows how many times the same alarm has occurred consecutively.
6.16	Multiple alarm 1	Simultaneously occurring alarm code (1) (“ - - - - ” is displayed if no alarm has occurred.)
6.17	Multiple alarm 2	Simultaneously occurring alarm code (2) (“ - - - - ” is displayed if no alarm has occurred.)
6.18	Terminal I/O signal status under communications control (displayed with the ON/OFF of LED segments)	Displays the ON/OFF state of digital I/O terminals transmitted via RS-485 communications.
6.19	Terminal input signal status under communications control (in hexadecimal)	
6.20	Terminal output signal status under communications control (in hexadecimal)	
6.21	Error sub code	Secondary error code for an alarm.
6.22	Running status 2	Displays running status 2 in 4-digit hexadecimal format.
6.23	Detected value	Displays the detected speed value when alarm occurred.
6.24	Running status 3	Displays running status 3 in 4-digit hexadecimal format.
6.25	Multiple alarm sub code	Secondary error code for a multiple alarm

Alarm Mode

If an abnormal condition arises, the protective function is invoked and issues an alarm, then the inverter automatically enters Alarm mode. At the same time, an alarm code appears on the LED monitor.

Releasing the alarm and switching to Running mode

Remove the cause of the alarm and press the **PRO RESET** key to release the alarm and return to Running mode. The alarm can be removed using the **PRO RESET** key only when the alarm code is displayed.

Displaying the status of inverter at the time of alarm

When the alarm code is displayed, you may check various running status information when the alarm occurred (output frequency and output current, etc.) by pressing the **FUNC DATA** key. The monitor item number and data for each running status information will be displayed alternately.

Further, you can view various information items on the running status of the inverter using the **▲ / ▼** key. The information displayed is the same as for menu number 6 “Alarm Information” in Programming mode. Pressing the **PRO RESET** key while the running status information is displayed returns to the alarm code display.

When the running status information is displayed after removal of the alarm cause, pressing the **PRO RESET** key twice returns to the alarm code display and releases the inverter from the alarm state. This means that the motor starts running if a run command has been received by this time.

Displaying the alarm history

It is possible to display the most recent 3 alarm codes in addition to the one currently displayed. Previous alarm codes can be displayed by pressing the **▲ / ▼** key while the current alarm code is displayed.

Switching to Programming mode

You can also switch to Programming mode by pressing “**STOP** + **PRO RESET** keys” simultaneously with the alarm displayed, and modify the function code data.

» Explanations of each display section

The monitor display section on the front of the E3N (Ethernet built in type) displays the inverter and communication status.

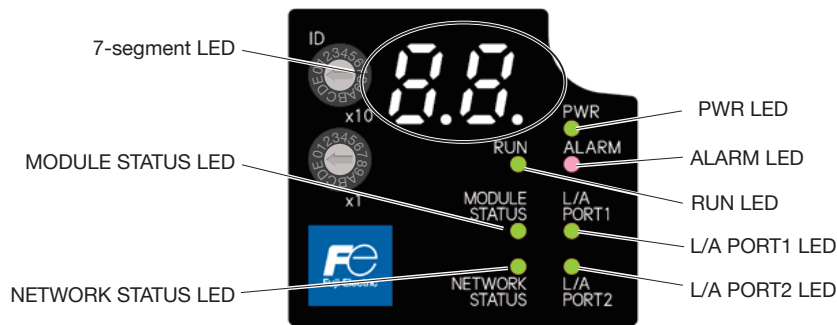

Names of each keypad part and overview of functions

Item	LED Monitor and Keys	Functions
7-segment LED indicators		This is a 2-digit, 7-segment LED monitor. It displays the inverter status.
LED display section	PWR (green)	Lights up when the inverter unit is energized.
	ALARM (red)	Lights up when an alarm has occurred and flashes when a warning has occurred.
	RUN (green)	Lights up when the inverter is running.
	MODULE STATUS (green/red)	The LED that lights up differs depending on the protocol. Refer to the explanations on the status LED for each protocol.
	NETWORK STATUS (green/red)	
	L/A PORT1 LED	
L/A PORT2 LED		

Keypad Operation

LED status Ethernet/IP

LED Name	Color	LED Status	Description	Remarks
MS (MODULE STATUS)	Green/Red	OFF	Power OFF	
		Alternate blinking	During self-diagnosis test at startup Each LED turns on for 0.25 seconds for indicator tests at startup MS (Green) ON→MS (Red) →NS (Green) →NS (Red) → OFF	Test performed for 1 second
	Green	ON	Operating normally	
		Blinking	IP address is not set when using DHCP.	
	Red	OFF	No failure	
		Blinking	Minor failure (recoverable)	Incorrect communication settings, etc.
		ON	Mounting failure or hardware failure (unrecoverable) *1	Err 4 occurs in the inverter
NS (NETWORK STATUS)	Green/Red	Alternate blinking	During self-diagnosis test at startup	Test performed for 1 second
		Green	OFF	Connection with scanner not established (IP address is not set)
	Blinking		Waiting for connection establishment with scanner (IP address is set)	Waiting for a communication connection request from the scanner.
	ON		Normally communicating with the scanner	
	Red	OFF	Normally communicating with the scanner	
		Blinking	A timeout occurred during communication with the scanner. - The communication cycle time is short.	*2
ON		There is a problem with the Ethernet cable or the settings. - Duplicate IP address	*2	
L/A PORT 1 L/A PORT 2	Green	OFF	Not connected	
		Blinking	Linking (in communication)	
		ON	Linking (not in communication)	

*1: Hardware failure status indicates an error that cannot continue operation such as a hard watchdog timeout, memory error, or exception interrupt.

*2: Err 5 may occur in the inverter. However, it is not displayed before starting IO communication. Err 5 may not be displayed according to the setting of o27.

LED status (PROFINET)

LED Name	Color	LED Status	Description	Remarks	
MS (MODULE STATUS)	Green/Red	OFF	Power OFF		
		Alternate blinking	During self-diagnosis test at startup Each LED turns on for 0.25 seconds for indicator tests at startup MS (Green) ON→MS (Red) →NS (Green) →NS (Red) → OFF	Test performed for 1 second	
	Green	ON	Operating normally		
		Red	OFF	Operating normally	
			Blinking	MAC address error	
		ON	Mounting failure or hardware failure (unrecoverable) *1	Err 4 occurs in the inverter	
NS (NETWORK STATUS)	Green/Red	Alternate blinking	During self-diagnosis test at startup	Test performed for 1 second	
		Green	OFF	Connection with master not established.	
	Blinking		Identifying the device. (The LED test with diagnostic tool)	Waiting for a communication connection request from the master	
	Single flash		Waiting for connection establishment with master.		
	ON		Normally communicating with the master.		
	Red	OFF	Normally communicating with the master.		
Single flash		Device Name is not registered.	*3		
		Double flash	IP address is not registered.		
L/A PORT 1 L/A PORT 2	Green	OFF	Not connected		
		Blinking	Linking (in communication)		
		ON	Linking (not in communication)		

*1: Hardware failure status indicates an error that cannot continue operation such as a hard watchdog timeout, memory error, or exception interrupt.

*3: It occurs when communication is disconnected after the start of communication or the Device Name is deleted during communication.
It does not occur before communication, or if there is no Device Name.







LED status (Modbus TCP)





LED Name	Color	LED Status	Description	Remarks
MS (MODULE STATUS)	Green/Red	OFF	Power OFF	
		Alternate blinking	During self-diagnosis test at startup Each LED turns on for 0.25 seconds for indicator tests at startup MS (Green) ON→MS (Red) →NS (Green) →NS (Red) → OFF	Test performed for 1 second
	Green	ON	Operating normally	
		Blinking	IP address is not set when using DHCP.	
	Red	OFF	No failure	
		Blinking	Minor failure (recoverable)	Incorrect communication settings, etc.
		ON	Mounting failure or hardware failure (unrecoverable) *1	Err4 occurs in the inverter
NS (NETWORK STATUS)	Green/Red	Alternate blinking	During self-diagnosis test at startup	Test performed for 1 second
	Green	OFF	—	
	Red	OFF	—	
L/A PORT 1 L/A PORT 2	Green	OFF	Not connected	
		Blinking	Linking (in communication)	
		ON	Linking (not in communication)	

*1: Hardware failure status indicates an error that cannot continue operation such as a hard watchdog timeout, memory error, or exception interrupt.

7-segment LED display

The front display of the display section changes depending on the inverter status. Details of descriptions are as follows.

Status	Code
When the power to the inverter is turned ON.	<i>f</i> <i>f</i> is displayed 1s after power on. 
Stop status	
Running	When the device is running in the forward direction, <i>f</i> is displayed on the left digit and the right digit rotates clockwise. 
	 The speed of the clockwise rotation varies depending on the operating frequency.
	When the device is running in the reverse direction, <i>r</i> is displayed on the left digit and the right digit rotates counterclockwise. 
	 The speed of the counterclockwise rotation varies depending on the operating frequency.

Status	Code
Alarm occurring	The alarm code display alternates.  For details of alarm codes, refer to Chapter 6 "6.3.1 Alarm code list".
Insufficient voltage (with run command)	
STO (with run command)	
Measuring the main capacitor capacity	
DC output	







Function Codes

Drive control

The FRENIC-Ace runs under any of the following control methods. Some function codes apply exclusively to the specific control method.

The enable or disable status is indicated with an icon for each control method within the permissible setting range field in the function code list table.

Icon example: Under V/f control Enable:  Disable: 







Function code table permissible setting range field	Control target (H18)	Control method (F42)
	Speed (H18=0)	V/f control Dynamic torque vector control (F42=1) V/f control with slip compensation (F42=2)
		V/f control with speed sensor (F42=3) Dynamic torque vector control with speed sensor (F42=4)
		Sensorless vector control (F42=5)
		Vector control with speed sensor (F42=6)
		Sensorless vector control (synchronous motors) (F42=15)
		Vector control with sensor (synchronous motors) (F42=16)
	Torque (H18=2, 3)	Vector control (F42=5,6,16)

For details on the control method, refer to "Function code F42".

Note) The FRENIC-Ace is a general-purpose inverter whose operation is customized by frequency-basis function codes, like conventional inverters. Under the speed-basis drive control, however, the control target is a motor speed, not a frequency, so convert the frequency to the motor speed according to the following expression.

Conversion formula
Motor speed (r/min) = 120 x frequency (Hz)/number of poles

Changes during operation

Symbol	Changes during operation	Apply and save data
Y*	Yes	When the data is changed using the  keys, it is immediately reflected in the inverter operation. However, the changed value is not saved in the inverter at this stage. To store data in the inverter, press the  key. If you abandon changes with the  key without saving with them with the  key, the data before the change will be reflected in the operation of the inverter.
Y	Yes	Even if you change the data using the  keys, the changes will not be reflected in the operation of the inverter until you press the  key to save the changes and reflect them in the operation of the inverter.
N	No	—

Copying data

Symbol	Copiability of data
Y	Data is copied.
Y1	Data is not copied if the inverter capacity differs.
Y2	Data is not copied if the voltage series differs.
N	Data is not copied.

Differences according to series

For the E3S/E3E series and the E3N series, the presence of some function codes and the choice of function code data may differ.
 Y: Configurable function code, N: Non-configurable (not displayed).

When the data selection range is different, such as in the case of function code F01, it is divided into [Basic type/EMC filter built-in type] and [Ethernet built-in type].

F codes :Fundamental functions

Function code	Name	Control method and Data setting range	Basic Type, EMC Filter Built-in type	Ethernet built-in Type	Change when running	Data copying
F00	Data protection	<p>V/f PGV/f SLV PGV PM SLV PM PGV TRQ</p> <p>0: No data protection, no digital setting protection 1: With data protection, no digital setting protection 2: No data protection, with digital setting protection 3: With data protection, with digital setting protection</p>	Y	N	Y	Y
F01	Frequency setting 1	<p>V/f PGV/f SLV PGV PM SLV PM PGV TRQ</p> <p>[Basic type / EMC filter built-in type] 0: Keypad key operation (▲ / ▼ keys) 1: Analog voltage input (Terminal [12]) (from 0 to ±10 VDC) 2: Analog current input (Terminal [C1](C1 function)) (4 to 20 mA DC) 3: Analog voltage input (Terminal [12]) + analog current input (Terminal [C1]) 5: Analog voltage input (Terminal [C1](V2 function)) (from 0 to ±10 VDC) 7: UP/DOWN control 8: Keypad key operation (▲ / ▼ keys) (with balanceless bumps) 10: Pattern operation 11: Digital input interface card OPC-DI (option) 12: Pulse train input</p> <p>[Ethernet built-in type] 1: Analog voltage input (Terminal [12]) (from 0 to ±10 VDC) 2: Analog current input (Terminal [C1](C1 function)) (4 to 20 mA DC) 3: Analog voltage input (Terminal [12]) + analog current input (Terminal [C1]) 5: Analog voltage input (Terminal [C1](V2 function)) (from 0 to ±10 VDC) 7: UP/DOWN control 10: Pattern operation</p>	Y	Y	N	Y
		<p>Y</p> <p>Y</p> <p>N</p> <p>Y</p>	Y	Y	N	Y
F02	Operation method	<p>V/f PGV/f SLV PGV PM SLV PM PGV TRQ</p> <p>0: Keypad operation (Rotation direction input: terminal block) 1: External signal (digital input) 2: Keypad operation (forward rotation) 3: Keypad operation (reverse rotation)</p>	Y	N	N	Y
F03	Maximum output frequency 1	<p>V/f PGV/f SLV PGV PM SLV PM PGV TRQ</p> <p>5.0 to 599.0 Hz</p>	Y	Y	N	Y
F04	Base frequency 1	<p>V/f PGV/f SLV PGV PM SLV PM PGV TRQ</p> <p>5.0 to 599.0 Hz</p>	Y	Y	N	Y
F05	Rated voltage at base frequency 1	<p>V/f PGV/f SLV PGV PM SLV PM PGV TRQ</p> <p>0: AVR disable (output voltage proportional to power voltage) 80 to 240 V: AVR operation (200V series) 160 to 500 V: AVR operation (400 V series)</p>	Y	Y	N	Y2
F06	Maximum output voltage 1	<p>V/f PGV/f SLV PGV PM SLV PM PGV TRQ</p> <p>80 to 240 V: AVR operation (200V series) 160 to 500 V: AVR operation (400 V series)</p>	Y	Y	N	Y2
F07	Acceleration time 1	<p>V/f PGV/f SLV PGV PM SLV PM PGV TRQ</p>	Y	Y	Y	Y
F08	Deceleration time 1	<p>0.00 to 6000s * 0.00 is for acceleration and deceleration time cancel (when performing soft-start and stop externally)</p>	Y	Y	Y	Y
F09	Torque boost 1	<p>V/f PGV/f SLV PGV PM SLV PM PGV TRQ</p> <p>0.0 to 20.0% (% value against base frequency voltage 1)</p>	Y	Y	Y*	Y
F10	Electronic thermal overload protection for motor 1 (Select motor characteristics)	<p>V/f PGV/f SLV PGV PM SLV PM PGV TRQ</p> <p>1: Enable (for a general-purpose motor with self-cooling fan) 2: Enable (for an inverter-driven motor with separately powered cooling fan)</p>	Y	Y	Y	Y
F11	(Operation level)	0.00 A (disable), current value of 1 to 135% of inverter rated current set with A unit	Y	Y	Y	Y1 Y2
F12	(Thermal time constant)	0.5 to 75.0min	Y	Y	Y	Y
F14	Restart mode after momentary power failure (operation selection)	<p>V/f PGV/f SLV PGV PM SLV PM PGV TRQ</p> <p>0: Trip immediately 1: Trip after a recovery from power failure 2: Trip after momentary deceleration is stopped 3: Continue to run (for heavy inertia load or general load) 4: Restart from frequency at power failure (for general load) 5: Restart from starting frequency</p>	Y	Y	Y	Y
F15	Frequency limiter (upper limit)	<p>V/f PGV/f SLV PGV PM SLV PM PGV TRQ</p>	Y	Y	Y	Y
F16	(Lower limit)	0.0 to 599.0Hz	Y	Y	Y	Y
F18	Bias (starting frequency)	<p>V/f PGV/f SLV PGV PM SLV PM PGV TRQ</p> <p>-100.00 to 100.00%</p>	Y	Y	Y*	Y

*2 A standard value is set for each capacity.

*3 The rated current of the motor is set. For details, refer to the FRENIC-Ace (E3) User's Manual.

Function Codes

F codes : Fundamental functions

Function code	Name	Control method and Data setting range	Basic Type, EMC Filter Built-in type	Ethernet built-in Type	Change when running	Data copying
F20	DC braking 1 (starting frequency)	V/f PGV/f SLV PGV PM SLV PM PGV TRO 0.0 to 60.0Hz	Y	Y	Y	Y
F21	(Operation level)	0 to 100% (HHD mode) 0 to 80% (HD/HND mode) 0 to 60% (HND mode) (Only FRN0001E3□-7G to FRN0012E3□-7G/FRN0012E3□-2G to FRN0020E3□-2G/FRN0007E3□-4G to FRN0012E3□-4G) 0 to 60 % (ND mode)	Y	Y	Y	Y
F22	(Braking time)	0.00 (disable): 0.01 to 30.00 s	Y	Y	Y	Y
F23	Starting frequency 1	V/f PGV/f SLV PGV PM SLV PM PGV TRO 0.0 to 60.0 Hz	Y	Y	Y	Y
F24	(Holding time)	0.00 to 10.00s 1.0 s is automatically set when F42 ≠ 15, 16 → F42 = 15, 16. 0.5 s is automatically set when F42 = 15, 16 → F42 ≠ 15, 16.	Y	Y	Y	Y
F25	Stop frequency	V/f PGV/f SLV PGV PM SLV PM PGV TRO 0.0 to 60.0Hz	Y	Y	Y	Y
F26	Motor sound (Carrier frequency)	V/f PGV/f SLV PGV PM SLV PM PGV TRO ND/HND Mode 0.75 to 10 kHz HD/HND Mode 0.75 to 16 kHz (FRN0001E3□-2G to FRN0088E3□-2G) 0.75 to 16 kHz (FRN0002E3□-4G to FRN0059E3□-4G) 0.75 to 10 kHz (FRN0115E3□-2G) 0.75 to 10 kHz (FRN0072E3□-4G) HHD Mode 0.75 to 16 kHz (FRN0001E3□-2G to FRN0115E3□-2G) 0.75 to 16 kHz (FRN0002E3□-4G to FRN0072E3□-4G)	Y	Y	Y*	Y
F27	(Tone)	V/f PGV/f SLV PGV PM SLV PM PGV TRO 0: Level 0 (disable) 1: Level 1 2: Level 2 3: Level 3	Y	Y	Y*	Y
F29	Terminal [FM1] (Operation selection)	V/f PGV/f SLV PGV PM SLV PM PGV TRO 0: Voltage output (0 to +10 VDC) 1: Current output (4 to 20 mA DC) 2: Current output (0 to 20 mA DC) 3: Pulse output	Y	Y	Y	Y
F30	(Output gain)	0 to 300%	Y	Y	Y*	Y
F31	(Function selection)	[Basic type / EMC filter built-in type] 0: Output frequency 1 (before slip compensation) 1: Output frequency 2 (after slip compensation) 2: Output current 3: Output voltage when alarm occurred 4: Output torque 5: Load factor 6: Power consumption 7: PID feedback value 8: Actual speed/estimated speed 9: DC link bus voltage 10: Universal AO 11: Analog output test (-) 13: Motor output 14: Calibration (+) 15: PID command (SV) 16: PID output (MV) 17: Master-follower angle deviation 18: Inverter cooling fin temperature 21: PG feedback value 22: Torque current command 26: Setting frequency (before acceleration/deceleration calculation) 111 to 124: Customizable logic output signal 1 to 14 [Ethernet built-in type] 0: Output frequency 1 (before slip compensation) 1: Output frequency 2 (after slip compensation) 2: Output current 3: Output voltage when alarm occurred 4: Output torque 5: Load factor 6: Power consumption 7: PID feedback value 8: Actual speed/estimated speed 9: DC link bus voltage 10: Universal AO 13: Motor output 14: Analog output test (-) 15: PID command (SV) 16: PID output (MV) 18: Inverter cooling fin temperature 22: Torque current command 26: Setting frequency (before acceleration/deceleration calculation) 111 to 124: Customizable logic output signal 1 to 14	Y	Y	Y	Y

Function code	Name	Control method and Data setting range	Basic Type, EMC Filter Built-in type	Ethernet built-in Type	Change when running	Data copying
F32	Terminal [FM2] (Operation selection)	0: Voltage output (0 to +10 VDC) 1: Current output (4 to 20 mA DC) 2: Current output (0 to 20 mA DC)	Y	N	Y	Y
F33	Terminal [FMP] (Pulse rate)	V/f PGV/f SLV PGV PM SLV PM PGV TRQ 25 to 32000 p/s (number of pulse at 100%)	Y	Y	Y*	Y
F34	Terminal [FM2] (Output gain)	0.1 to 300%	Y	N	Y*	Y
F35	(Function selection)	Same as F31	Y	N	Y	Y
F37	Load selection/ Auto torque boost/ Auto energy-saving operation 1	V/f PGV/f SLV PGV PM SLV PM PGV TRQ 0: Quadratic-torque load 1: Constant torque load 2: Auto torque boost 3: Auto energy-saving operation (quadratic-torque load) 4: Auto energy-saving operation (constant torque load) 5: Auto energy-saving operation with auto torque boost	Y	Y	N	Y
F38	Stop frequency (detection mode)	V/f PGV/f SLV PGV PM SLV PM PGV TRQ 0: Speed detection value / estimated speed 1: Reference speed	Y	N	N	Y
F39	(Holding time)	V/f PGV/f SLV PGV PM SLV PM PGV TRQ 0.00 to 10.00s	Y	Y	Y	Y
F40	Torque limiter 1-1	V/f PGV/f SLV PGV PM SLV PM PGV TRQ	Y	Y	Y	Y
F41	Torque limiter 1-2	-300 to 0 to 300%; 999 (Disable)	Y	Y	Y	Y
F42	Drive control selection 1	V/f PGV/f SLV PGV PM SLV PM PGV TRQ [Basic type / EMC filter built-in type] 0: V/f control without slip compensation 1: Dynamic torque vector control 2: V/f control with slip compensation 3: V/f control with speed sensor 4: Dynamic torque vector control with sensor 5: Sensorless vector control 6: Vector control with speed sensor 15: Sensorless vector control (synchronous motors) 16: Vector control with sensor (synchronous motors) [Ethernet built-in type] 0: V/f control without slip compensation 1: Dynamic torque vector control 2: V/f control with slip compensation 5: Sensorless vector control 15: Sensorless vector control (synchronous motors)	Y	Y	N	Y
F43	Current limiter (mode selection)	V/f PGV/f SLV PGV PM SLV PM PGV TRQ 0: Disable 1: Enable at constant speed (disable during ACC/DEC) 2: Enable during ACC/constant speed operation (disable during DEC)	Y	Y	Y	Y
F44	(Operation level)	20 to 200% (rated current of the inverter for 100%)	Y	Y	Y	Y
F50	Electronic thermal overload (for braking resistor protection)	V/f PGV/f SLV PGV PM SLV PM PGV TRQ 1 to 9000 kW OFF (cancel)	Y	Y	Y	Y1 Y2
F51	(Permissible average loss)	0.001 to 99.99kW	Y	Y	Y	Y1 Y2
F52	(Braking resistance value)	0.00: No resistance necessary method (FRENIC-Multi compatible operation) 0.01 to 999Ω	Y	Y	Y	Y1 Y2
F58	Terminal [FM1] (Filter)	V/f PGV/f SLV PGV PM SLV PM PGV TRQ 0.00 to 5.00s	Y	Y	Y	Y
F59	(Bias)	-100.0 to 100.0%	Y	Y	Y*	Y
F62	Terminal [FM2] (Filter)	0.00 to 5.00s	Y	N	Y	Y
F63	(Bias)	-100.0 to 100.0%	Y	N	Y*	Y
F80	Switching between ND, HD, HND and HHD drive modes	V/f PGV/f SLV PGV PM SLV PM PGV TRQ 0: HHD specification 1: HND specification 3: HD specification 4: ND specification	Y	Y	N	Y

*12 FRN 0.1 to 15E3S/E/T/N-2J/4J will be 180% and FRN 18.5 to 22E3S/E/T/N-2J/4J will be 160%.

Features

Main application examples

Model variations

Type number nomenclature

Standard specifications

Common specifications

Terminal specifications

Basic wiring diagram

External dimensions

Keypad

Function codes

Options

Product warranty

Function Codes

E codes : Extension Terminal Functions (terminal functions)

Function code	Name	Control method and Data setting range	Basic Type, EMC Filter Built-in type	Ethernet built-in Type	Change when running	Data copying
E01	Terminal [X1] (Function selection)	Table 1 Refer to E01 to E05 in the control input terminal setting table.	Y	Y	N	Y
E02	Terminal [X2]		Y	Y	N	Y
E03	Terminal [X3]		Y	Y	N	Y
E04	Terminal [X4]		Y	N	N	Y
E05	Terminal [X5]		Y	N	N	Y

Table 1 Control input terminal setting table (Y is a selectable choice, N is a non-selectable choice)

Function code and Name				Control method and Data setting range	Basic Type, EMC Filter Built-in type	Ethernet built-in Type
E01 to E05	E70	E98,E99	o101 to o113			
Terminals [X1] to [X5]	For remote keypad TP-E2 M/Shift keys	Terminals [FWD][REV]	Terminals [I1] to [I13] (for OPC-DI)			
Y	Y	Y	Y	V/f PGV/f SLV PGV PM SLV PM PGV TRQ 0 (1000): Multistep frequency selection (0 to 1 steps) [SS1]	Y	Y
				1 (1001): Select multistep frequency (0 to 3 steps) [SS2]	Y	Y
				2 (1002): Select multistep frequency (0 to 7 steps) [SS4]	Y	Y
				3 (1003): Select multistep frequency (0 to 15 steps) [SS8]	Y	Y
Y	Y	Y	Y	4 (1004): Select ACC/DEC time (2 steps) [RT1]	Y	Y
				5 (1005): Select ACC/DEC time (4 steps) [RT2]	Y	Y
Y	Y	Y	Y	V/f PGV/f SLV PGV PM SLV PM PGV TRQ 6 (1006): Select 3-wire operation [HLD]	Y	Y
Y	Y	Y	Y	7 (1007): Coast to a stop command [BX]	Y	Y
Y	N	Y	Y	8 (1008): Reset alarm (Abnormal) [RST]	Y	Y
Y	N	Y	Y	9 (1009): External alarm (9 = Active OFF/1009 = Active ON) [THR]	Y	Y
Y	Y	Y	Y	V/f PGV/f SLV PGV PM SLV PM PGV TRQ 10 (1010): Ready for jogging [JOG]	Y	Y
Y	Y	Y	Y	11 (1011): Select frequency setting 2/ frequency setting 1 [Hz2/Hz1]	Y	Y
Y	Y	Y	Y	V/f PGV/f SLV PGV PM SLV PM PGV TRQ 12 (1012): Select motor 2 [M2]	Y	Y
Y	Y	Y	Y	V/f PGV/f SLV PGV PM SLV PM PGV TRQ 13: DC braking command PM.SLV is valid only when P30 = 0 [DCBRK]	Y	Y
Y	Y	Y	Y	V/f PGV/f SLV PGV PM SLV PM PGV TRQ 14 (1014): Select torque limit 2/ torque limit 1 [TL2/TL1]	Y	Y
Y	N	Y	Y	V/f PGV/f SLV PGV PM SLV PM PGV TRQ 15: Switch to commercial power (50 Hz) [SW50]	Y	Y
				16: Switch to commercial power (60 Hz) [SW60]	Y	Y
Y	N	Y	Y	V/f PGV/f SLV PGV PM SLV PM PGV TRQ 17 (1017): UP command [UP]	Y	Y
				18 (1018): DOWN command [DOWN]	Y	Y
Y	Y	Y	Y	V/f PGV/f SLV PGV PM SLV PM PGV TRQ 19 (1019): Allow function code editing (data change enabled) [WE-KP]	Y	N
Y	Y	Y	Y	V/f PGV/f SLV PGV PM SLV PM PGV TRQ 20 (1020): Cancel PID control [Hz/PID]	Y	Y
Y	Y	Y	Y	21 (1021): Switch normal/ inverse operation [IVS]	Y	Y
Y	N	Y	Y	V/f PGV/f SLV PGV PM SLV PM PGV TRQ 22 (1022): Interlock [IL]	Y	Y
Y	Y	Y	Y	V/f PGV/f SLV PGV PM SLV PM PGV TRQ 23 (1023): Cancel torque control [Hz/TRQ]	Y	Y
Y	Y	Y	Y	V/f PGV/f SLV PGV PM SLV PM PGV TRQ 24 (1024): Select link operation (RS-485, BUS option) [LE]	Y	Y
Y	N	Y	Y	25 (1025): Universal DI [U-DI]	Y	Y
Y	Y	Y	Y	V/f PGV/f SLV PGV PM SLV PM PGV TRQ 26 (1026): Select auto search for idling motor speed at starting [STM]	Y	Y
Y	Y	Y	Y	V/f PGV/f SLV PGV PM SLV PM PGV TRQ 30 (1030): Force to stop (30 = Active OFF/1030 = Active ON) [STOP]	Y	Y
Y	Y	Y	Y	V/f PGV/f SLV PGV PM SLV PM PGV TRQ 32 (1032): Pre-excite [EXITE]	Y	Y
Y	Y	Y	Y	V/f PGV/f SLV PGV PM SLV PM PGV TRQ 33 (1033): Reset PID integral and differential terms [PID-RST]	Y	Y
				34 (1034): Hold PID integral term [PID-HLD]	Y	Y

Function code and Name				Control method and Data setting range	Basic Type, EMC Filter Built-in type	Ethernet built-in Type
E01 to E05	E70	E98,E99	o101 to o113			
Terminals [X1] to [X5]	For remote keypad TP-E2 M/Shift keys	Terminals [FWD][REV]	Terminals [I1] to [I13] (for OPC-DI)			
Y	Y	Y	Y	V/f PGV/f SLV PGV PM SLV PM PGV TRQ 35 (1035): Local (keypad) command selection [LOC]	Y	N
Y	Y	Y	Y	38 (1038): Drive permission [RE]	Y	Y
Y	Y	Y	Y	V/f PGV/f SLV PGV PM SLV PM PGV TRQ 39: Condensation prevention [DWP]	Y	Y
Y	N	Y	Y	V/f PGV/f SLV PGV PM SLV PM PGV TRQ 42 (1042): Activate the limit switch at start point [LS]	Y	N
Y	Y	Y	Y	V/f PGV/f SLV PGV PM SLV PM PGV TRQ 43 (1043): Start / Reset [S/R]	Y	N
Y	Y	Y	Y	V/f PGV/f SLV PGV PM SLV PM PGV TRQ 44 (1044): Serial pulse receiving mode [SPRM]	Y	N
Y	Y	Y	Y	V/f PGV/f SLV PGV PM SLV PM PGV TRQ 45 (1045): Enter the return mode [RTN]	Y	N
Y	Y	Y	Y	V/f PGV/f SLV PGV PM SLV PM PGV TRQ 46 (1046): Overload stop enable command [OLS]	Y	Y
Y	Y	Y	Y	V/f PGV/f SLV PGV PM SLV PM PGV TRQ 47 (1047): Servo lock command [LOCK]	Y	N
Y ^{*1}	N	N	N	V/f PGV/f SLV PGV PM SLV PM PGV TRQ 48: Pulse train input ^{*1} Terminal [X5] only (E05) [PIN]	Y	N
Y ^{*2}	N	Y	Y	49 (1049): Pulse train sign terminal ^{*2} Excluded the terminal [X5] (E01 to E04) [SIGN]	Y	N
Y	Y	Y	Y	V/f PGV/f SLV PGV PM SLV PM PGV TRQ 58(1058) :UP/DOWN frequency clear [STZ]	Y	Y
Y	Y	Y	Y	V/f PGV/f SLV PGV PM SLV PM PGV TRQ 59 (1059): Battery operation selection [BATRY]	Y	Y
Y	Y	Y	Y	V/f PGV/f SLV PGV PM SLV PM PGV TRQ 60 (1060): Select torque bias 1 [TB1]	Y	Y
				61 (1061): Select torque bias 2 [TB2]	Y	Y
				62 (1062): Hold torque bias [H-TB]	Y	Y
Y	N	Y	Y	V/f PGV/f SLV PGV PM SLV PM PGV TRQ 65 (1065): Check brake [BRKE]	Y	Y
Y	Y	Y	Y	V/f PGV/f SLV PGV PM SLV PM PGV TRQ 70 (1070): Cancel line speed control [Hz/LSC]	Y	N
				71 (1071): Hold line speed control frequency in the memory [LSC-HLD]	Y	N
Y	N	Y	Y	V/f PGV/f SLV PGV PM SLV PM PGV TRQ 72 (1072): Count the run time of commercial power-driven motor 1 [CRUN-M1]	Y	Y
				73 (1073): Count the run time of commercial power-driven motor 2 [CRUN-M2]	Y	Y
Y	Y	Y	Y	V/f PGV/f SLV PGV PM SLV PM PGV TRQ 76 (1076): Select droop control [DROOP]	Y	Y
Y	Y	Y	Y	V/f PGV/f SLV PGV PM SLV PM PGV TRQ 78 (1078): Speed control parameter selection 1 [MPRM1]	Y	Y
				79 (1079): Speed control parameter selection 2 [MPRM2]	Y	Y
Y	Y	Y	Y	V/f PGV/f SLV PGV PM SLV PM PGV TRQ 80 (1080): Cancel customizable logic [CLC]	Y	Y
				81 (1081): Clear all customizable logic timers [CLTC]	Y	Y
Y	Y	Y	Y	V/f PGV/f SLV PGV PM SLV PM PGV TRQ 82 (1082): Anti-regenerative control cancel [AR-CCL]	Y	Y
Y	Y	Y	Y	V/f PGV/f SLV PGV PM SLV PM PGV TRQ 83 (1083): PG input switching [PG-SEL]	Y	N
Y	Y	Y	Y	V/f PGV/f SLV PGV PM SLV PM PGV TRQ 84 (1084): Acceleration/deceleration cancel (bypass) [BPS]	Y	Y
Y	N	Y	Y	V/f PGV/f SLV PGV PM SLV PM PGV TRQ 94: Forward rotation JOG [FJOG]	Y	Y
				95: Reverse rotation JOG [RJOG]	Y	Y
Y	Y	Y	Y	V/f PGV/f SLV PGV PM SLV PM PGV TRQ 97 (1097): Direction command [DIR]	Y	Y
N	N	Y	Y	V/f PGV/f SLV PGV PM SLV PM PGV TRQ 98: Run forward command [FWD]	Y	Y
				99: Run reverse command [REV]	Y	Y

Features

Main application examples

Model variations

Type number nomenclature

Standard specifications

Common specifications

Terminal specifications

Basic wiring diagram

External dimensions

Keypad

Function codes

Options

Product warranty

Function Codes

E codes : Extension Terminal Functions (terminal functions)

Table 1 Control input terminal setting table

Function code and Name				Control method and Data setting range	Basic Type, EMC Filter Built-in type	Ethernet built-in Type
E01 to E05	E70	E98,E99	o101 to o113			
Terminals [X1] to [X5]	For remote keypad TP-E2 M/Shift keys	Terminals [FWD][REV]	Terminals [I1] to [I13] (for OPC-D)			
Y	Y	Y	Y	<div style="display: flex; justify-content: space-between; font-size: 8px;"> V/f PGV/f SLV PGV PM SLV PM PGV TRQ </div> 100: No assignment [NONE]	Y	Y
Y	Y	Y	Y	<div style="display: flex; justify-content: space-between; font-size: 8px;"> V/f PGV/f SLV PGV PM SLV PM PGV TRQ </div> 119 (1119): Speed regulator P selection [P-SEL]	Y	N
Y	Y	Y	Y	<div style="display: flex; justify-content: space-between; font-size: 8px;"> V/f PGV/f SLV PGV PM SLV PM PGV TRQ </div> 121 (1121) to 129(1129): Customizable logic input 1 to 9 "CLI1" [CLI1] to [CLI9]	Y	Y
Y	Y	Y	Y	<div style="display: flex; justify-content: space-between; font-size: 8px;"> V/f PGV/f SLV PGV PM SLV PM PGV TRQ </div> 134 (1134): Forced operation command [FMS]	Y	Y
				<div style="display: flex; justify-content: space-between; font-size: 8px;"> V/f PGV/f SLV PGV PM SLV PM PGV TRQ </div> 135 (1135): Travel/absolute position switching [INC/ABS]	Y	N
				<div style="display: flex; justify-content: space-between; font-size: 8px;"> V/f PGV/f SLV PGV PM SLV PM PGV TRQ </div> 136 (1136): Orientation command [ORT]	Y	N
Y	Y	Y	Y	142 (1142): Position preset command [P-PRESET]	Y	N
Y	Y	Y	Y	144 (1144): Positioning data change command [POS-SET]	Y	N
Y	Y	Y	Y	145 (1145): Positioning data selection [POS-SEL1]	Y	N
Y	Y	Y	Y	146 (1146): Positioning data selection [POS-SEL2]	Y	N
Y	Y	Y	Y	147 (1147): Positioning data selection 4 [POS-SEL4]	Y	N
Y	Y	Y	Y	<div style="display: flex; justify-content: space-between; font-size: 8px;"> V/f PGV/f SLV PGV PM SLV PM PGV TRQ </div> 171 (1171): PID control multistage command 1 [PID-SS1]	Y	Y
				<div style="display: flex; justify-content: space-between; font-size: 8px;"> V/f PGV/f SLV PGV PM SLV PM PGV TRQ </div> 172 (1172): PID control multistage command 2 [PID-SS2]	Y	Y

* Inside the () is the negative logic signal (OFF at short-circuit).

E codes : Extension Terminal Functions (terminal functions)

Function code	Name	Control method and Data setting range	Basic Type, EMC Filter Built-in type	Ethernet built-in Type	Change when running	Data copying
E10	Acceleration time 2	<input type="checkbox"/> V/f <input type="checkbox"/> PGV/f <input type="checkbox"/> SLV <input type="checkbox"/> PGV <input type="checkbox"/> PM SLV <input type="checkbox"/> PM PGV <input type="checkbox"/> TRQ	Y	Y	Y	Y
E11	Deceleration time 2	0.00 to 6000 s	Y	Y	Y	Y
E12	Acceleration time 3	* 0.00 is for acceleration and deceleration time cancel (when performing soft-start and stop externally)	Y	Y	Y	Y
E13	Deceleration time 3		Y	Y	Y	Y
E14	Acceleration time 4		Y	Y	Y	Y
E15	Deceleration time 4		Y	Y	Y	Y
E16	Torque limiter 2-1	<input type="checkbox"/> V/f <input type="checkbox"/> PGV/f <input type="checkbox"/> SLV <input type="checkbox"/> PGV <input type="checkbox"/> PM SLV <input type="checkbox"/> PM PGV <input type="checkbox"/> TRQ	Y	Y	Y	Y
E17	Torque limiter 2-2	-300 to 0 to 300%; 999 (Disable)	Y	Y	Y	Y
E20	Terminal [Y1] (Function selection)	Table 2 Refer to E20 to E27 in the control output terminal setting table.	Y	Y	N	Y
E21	Terminal [Y2]		Y	N	N	Y
E27	Terminal [30A/B/C] (Ry output)		Y	Y	N	Y

Table 2 Control output terminal setting table (Y is a selectable choice, N is a non-selectable choice)

Function code and Name				Control method and Data setting range	Basic Type, EMC Filter Built-in type	Ethernet built-in Type
E20 to E21, E27	E71	o01 to o03	o121 to o128			
Terminals [Y1] to [Y2], [30A/B/C]	For remote keypad M-LED M/Shift keys	Terminals [Y6A/C] to [Y8A/C] (for OPC-RY)	Terminals [01] to [08] (for OPC-DIO)			
Y	Y	Y	Y	<input type="checkbox"/> V/f <input type="checkbox"/> PGV/f <input type="checkbox"/> SLV <input type="checkbox"/> PGV <input type="checkbox"/> PM SLV <input type="checkbox"/> PM PGV <input type="checkbox"/> TRQ 0 (1000): Inverter running [RUN]	Y	Y
Y	Y	Y	Y	<input type="checkbox"/> V/f <input type="checkbox"/> PGV/f <input type="checkbox"/> SLV <input type="checkbox"/> PGV <input type="checkbox"/> PM SLV <input type="checkbox"/> PM PGV <input type="checkbox"/> TRQ 1 (1001): Frequency (speed) arrival [FAR]	Y	Y
Y	Y	Y	Y	<input type="checkbox"/> V/f <input type="checkbox"/> PGV/f <input type="checkbox"/> SLV <input type="checkbox"/> PGV <input type="checkbox"/> PM SLV <input type="checkbox"/> PM PGV <input type="checkbox"/> TRQ 2 (1002): Frequency (speed) detected [FDT]	Y	Y
Y	Y	Y	Y	3 (1003): Under voltage detected (inverter stopped) [LU]	Y	Y
Y	Y	Y	Y	4 (1004): Detected torque polarity [B/D]	Y	Y
Y	Y	Y	Y	5 (1005): Inverter output limiting [IOL]	Y	Y
Y	Y	Y	Y	6 (1006): Auto-restarting after momentary power failure [IPF]	Y	Y
Y	Y	Y	Y	7 (1007): Motor overload early warning [OL]	Y	Y
Y	Y	Y	Y	8 (1008): Keypad operation [KP]	Y	N
Y	Y	Y	Y	10 (1010): Inverter ready to run [RDY]	Y	Y
Y	N	Y	Y	<input type="checkbox"/> V/f <input type="checkbox"/> PGV/f <input type="checkbox"/> SLV <input type="checkbox"/> PGV <input type="checkbox"/> PM SLV <input type="checkbox"/> PM PGV <input type="checkbox"/> TRQ 15 (1015): Switch MC on the input power lines [AX]	Y	Y
				<input type="checkbox"/> V/f <input type="checkbox"/> PGV/f <input type="checkbox"/> SLV <input type="checkbox"/> PGV <input type="checkbox"/> PM SLV <input type="checkbox"/> PM PGV <input type="checkbox"/> TRQ 16 (1016): Pattern operation stage transition [TU]	Y	Y
Y	Y	Y	Y	17 (1017): Pattern operation cycle completed [TO]	Y	Y
				18 (1018): Pattern operation stage 1 [STG1]	Y	Y
				19 (1019): Pattern operation stage 2 [STG2]	Y	Y
				20 (1020): Pattern operation stage 4 [STG4]	Y	Y
Y	Y	Y	Y	<input type="checkbox"/> V/f <input type="checkbox"/> PGV/f <input type="checkbox"/> SLV <input type="checkbox"/> PGV <input type="checkbox"/> PM SLV <input type="checkbox"/> PM PGV <input type="checkbox"/> TRQ 21 (1021): Frequency (speed) arrival 2 [FAR2]	Y	Y
Y	Y	Y	Y	<input type="checkbox"/> V/f <input type="checkbox"/> PGV/f <input type="checkbox"/> SLV <input type="checkbox"/> PGV <input type="checkbox"/> PM SLV <input type="checkbox"/> PM PGV <input type="checkbox"/> TRQ 22 (1022): Inverter output limiting with delay [IOL2]	Y	Y
Y	Y	Y	Y	<input type="checkbox"/> V/f <input type="checkbox"/> PGV/f <input type="checkbox"/> SLV <input type="checkbox"/> PGV <input type="checkbox"/> PM SLV <input type="checkbox"/> PM PGV <input type="checkbox"/> TRQ 25 (1025): Cooling fan in operation [FAN]	Y	Y
Y	Y	Y	Y	<input type="checkbox"/> V/f <input type="checkbox"/> PGV/f <input type="checkbox"/> SLV <input type="checkbox"/> PGV <input type="checkbox"/> PM SLV <input type="checkbox"/> PM PGV <input type="checkbox"/> TRQ 26 (1026): Auto-resetting [TRY]	Y	Y
Y	N	N	N	<input type="checkbox"/> V/f <input type="checkbox"/> PGV/f <input type="checkbox"/> SLV <input type="checkbox"/> PGV <input type="checkbox"/> PM SLV <input type="checkbox"/> PM PGV <input type="checkbox"/> TRQ 27 (1027): Universal DO [U-DO]	Y	Y
Y	Y	Y	Y	<input type="checkbox"/> V/f <input type="checkbox"/> PGV/f <input type="checkbox"/> SLV <input type="checkbox"/> PGV <input type="checkbox"/> PM SLV <input type="checkbox"/> PM PGV <input type="checkbox"/> TRQ 28 (1028): Heat sink overheat early warning [OH]	Y	Y
Y	Y	Y	Y	<input type="checkbox"/> V/f <input type="checkbox"/> PGV/f <input type="checkbox"/> SLV <input type="checkbox"/> PGV <input type="checkbox"/> PM SLV <input type="checkbox"/> PM PGV <input type="checkbox"/> TRQ 29 (1029): Master-follower operation complete [SY]	Y	N
Y	Y	Y	Y	<input type="checkbox"/> V/f <input type="checkbox"/> PGV/f <input type="checkbox"/> SLV <input type="checkbox"/> PGV <input type="checkbox"/> PM SLV <input type="checkbox"/> PM PGV <input type="checkbox"/> TRQ 30 (1030): Lifetime alarm [LIFE]	Y	Y
Y	Y	Y	Y	<input type="checkbox"/> V/f <input type="checkbox"/> PGV/f <input type="checkbox"/> SLV <input type="checkbox"/> PGV <input type="checkbox"/> PM SLV <input type="checkbox"/> PM PGV <input type="checkbox"/> TRQ 31 (1031): Frequency (speed) detected 2 [FDT2]	Y	Y
Y	Y	Y	Y	<input type="checkbox"/> V/f <input type="checkbox"/> PGV/f <input type="checkbox"/> SLV <input type="checkbox"/> PGV <input type="checkbox"/> PM SLV <input type="checkbox"/> PM PGV <input type="checkbox"/> TRQ 33 (1033): Reference loss detected [REF OFF]	Y	Y

Function Codes

Function code and Name				Control method and Data setting range	Basic Type, EMC Filter Built-in type	Ethernet built-in Type
E20 to E21, E27	E71	o01 to o03	o121 to o128			
Terminals [Y1] to [Y2], [30A/B/C]	For remote keypad M-LED M/Shift keys	Terminals [Y6A/C] to [Y8A/C] (for OPC-RY)	Terminals [01] to [08] (for OPC-DIO)			
Y	Y	Y	Y	V/f PGV/f SLV PGV PM SLV PM PGV TRQ 35 (1035): Inverter outputting [RUN2]	Y	Y
Y	Y	Y	Y	V/f PGV/f SLV PGV PM SLV PM PGV TRQ 36 (1036): Overload prevention controlling [OLP]	Y	Y
Y	Y	Y	Y	V/f PGV/f SLV PGV PM SLV PM PGV TRQ 37 (1037): Current detected [ID]	Y	Y
Y	Y	Y	Y	38 (1038): Current detected 2 [ID2]	Y	Y
Y	Y	Y	Y	39 (1039): Current detected 3 [ID3]	Y	Y
Y	Y	Y	Y	41 (1041): Low current detected [IDL]	Y	Y
Y	Y	Y	Y	V/f PGV/f SLV PGV PM SLV PM PGV TRQ 42 (1042): PID alarm [PID-ALM]	Y	Y
Y	Y	Y	Y	43 (1043): Under PID control [PID-CTL]	Y	Y
Y	Y	Y	Y	44 (1044): Under sleep mode of PID control [PID-STP]	Y	Y
Y	Y	Y	Y	V/f PGV/f SLV PGV PM SLV PM PGV TRQ 45 (1045): Low torque detected [U-TL]	Y	Y
Y	Y	Y	Y	46 (1046): Torque detected 1 [TD1]	Y	Y
Y	Y	Y	Y	47 (1047): Torque detected 2 [TD2]	Y	Y
Y	Y	Y	Y	V/f PGV/f SLV PGV PM SLV PM PGV TRQ 48 (1048): Motor 1 selected [SWM1]	Y	Y
Y	Y	Y	Y	49 (1049): Motor 2 selected [SWM2]	Y	Y
Y	Y	Y	Y	V/f PGV/f SLV PGV PM SLV PM PGV TRQ 52 (1052): Forward rotation [FRUN]	Y	Y
Y	Y	Y	Y	53 (1053): Reverse rotation [RRUN]	Y	Y
Y	Y	Y	Y	V/f PGV/f SLV PGV PM SLV PM PGV TRQ 54 (1054): Under remote mode [RMT]	Y	Y
Y	Y	Y	Y	V/f PGV/f SLV PGV PM SLV PM PGV TRQ 55(1055): Input of run command [AX2]	Y	Y
Y	Y	Y	Y	V/f PGV/f SLV PGV PM SLV PM PGV TRQ 56 (1056): Motor overheat detected by thermistor [THM]	Y	Y
Y	Y	Y	Y	V/f PGV/f SLV PGV PM SLV PM PGV TRQ 57 (1057): Mechanical brake control [BRKS]	Y	Y
Y	Y	Y	Y	V/f PGV/f SLV PGV PM SLV PM PGV TRQ 58 (1058): Frequency (speed) detected 3 [FDT3]	Y	Y
Y	Y	Y	Y	V/f PGV/f SLV PGV PM SLV PM PGV TRQ 59 (1059): Current input wire break detection (terminal [C1] and [C2])[C1OFF]	Y	Y
Y	Y	Y	Y	V/f PGV/f SLV PGV PM SLV PM PGV TRQ 70 (1070): Speed valid [DNZS]	Y	Y
Y	Y	Y	Y	V/f PGV/f SLV PGV PM SLV PM PGV TRQ 71 (1071): Speed agreement [DSAG]	Y	Y
Y	Y	Y	Y	V/f PGV/f SLV PGV PM SLV PM PGV TRQ 72 (1072): Frequency (speed) arrival 3 [FAR3]	Y	Y
Y	Y	Y	Y	V/f PGV/f SLV PGV PM SLV PM PGV TRQ 76 (1076): Speed mismatch [PG-ERR]	Y	Y
Y	Y	Y	Y	V/f PGV/f SLV PGV PM SLV PM PGV TRQ 77 (1077): Low DC link bus voltage detection [U-EDC]	Y	Y
Y	Y	Y	Y	V/f PGV/f SLV PGV PM SLV PM PGV TRQ 79 (1079): During decelerating at momentary power failure [IPF2]	Y	Y
Y	Y	Y	Y	V/f PGV/f SLV PGV PM SLV PM PGV TRQ 80(1080): Stop position override alarm [OT]	Y	N
Y	Y	Y	Y	V/f PGV/f SLV PGV PM SLV PM PGV TRQ 81(1081): Under position [TO]	Y	N
Y	Y	Y	Y	V/f PGV/f SLV PGV PM SLV PM PGV TRQ 82 (1082): Positioning complete [PSET]	Y	N
Y	Y	Y	Y	V/f PGV/f SLV PGV PM SLV PM PGV TRQ 83 (1083): Current position count over-flowed	Y	Y
Y	Y	Y	Y	V/f PGV/f SLV PGV PM SLV PM PGV TRQ 84 (1084): Maintenance timer counted up [MNT]	Y	Y
Y	Y	Y	Y	V/f PGV/f SLV PGV PM SLV PM PGV TRQ 87 (1087): Frequency arrival and detected [FARFDT]	Y	Y

E codes : Extension Terminal Functions (terminal functions)

Table 2 Control input terminal setting table (Y is a selectable choice, N is a non-selectable choice)

Function code and Name				Control method and Data setting range	Basic Type, EMC Filter Built-in type	Ethernet built-in Type
E20 to E21, E27	E71	o01 to o03	o121 to o128			
Terminals [Y1] to [Y2], [30A/B/C]	For remote keypad M-LED M/Shift keys	Terminals [Y6A/C] to [Y8A/C] (for OPC-RY)	Terminals [01] to [08] (for OPC-DIO)			
Y	N	Y	Y	V/f PGV/f SLV PGV PM SLV PM PGV TRQ 90 (1090): Alarm content 1 [AL1] 91 (1091): Alarm content 2 [AL2] 92 (1092): Alarm content 4 [AL4] 93 (1093): Alarm content 8 [AL8]	Y	Y
Y	Y	Y	Y	V/f PGV/f SLV PGV PM SLV PM PGV TRQ 95 (1095): Forced operation [FMRUN]	Y	Y
Y	Y	Y	Y	V/f PGV/f SLV PGV PM SLV PM PGV TRQ 98 (1098): Light alarm [L-ALM] 99 (1099): Alarm output [ALM]	Y	Y
N	Y	N	N	V/f PGV/f SLV PGV PM SLV PM PGV TRQ 100: No assignment [NONE]	Y	Y
Y	Y	Y	Y	V/f PGV/f SLV PGV PM SLV PM PGV TRQ 101 (1101): EN circuit failure detected [DECF] 102 (1102): EN terminal input OFF [ENOFF]	Y	Y
Y	Y	Y	Y	V/f PGV/f SLV PGV PM SLV PM PGV TRQ 105 (1105): Braking transistor broken [DBAL]	Y	Y
Y	Y	Y	Y	V/f PGV/f SLV PGV PM SLV PM PGV TRQ 111 (1111) to 124(1124): Customizable logic output signal 1 to 14 [CLO1] to [CLO14]	Y	Y
Y	N	Y	Y	V/f PGV/f SLV PGV PM SLV PM PGV TRQ 125 (1125): Integral power pulse output [POUT]	Y	Y
Y	Y	Y	Y	V/f PGV/f SLV PGV PM SLV PM PGV TRQ 131 (1131): Speed limiting [S-LIM]	Y	Y
Y	Y	Y	Y	V/f PGV/f SLV PGV PM SLV PM PGV TRQ 132 (1132): Torque limit level [T-LIM]	Y	Y
Y	Y	Y	Y	V/f PGV/f SLV PGV PM SLV PM PGV TRQ 133 (1133): Low current detection [IDL2]	Y	Y
Y	Y	Y	Y	V/f PGV/f SLV PGV PM SLV PM PGV TRQ 251(1251): Shift key ON/OFF status [MTGL]	Y	N

* Inside the () is the negative logic signal (OFF at short-circuit)

Features

Main application examples

Model variations

Type number nomenclature

Standard specifications

Common specifications

Terminal specifications

Basic wiring diagram

External dimensions

Keypad

Function codes

Options

Product warranty

Function Codes

Function code	Name	Control method and Data setting range	Basic Type, EMC Filter Built-in type	Ethernet built-in Type	Change when running	Data copying
E29	Frequency arrival delay timer (FAR2)	<input type="checkbox"/> V/f <input type="checkbox"/> PGV/f <input type="checkbox"/> SLV <input type="checkbox"/> PGV <input type="checkbox"/> PM SLV <input type="checkbox"/> PM PGV <input type="checkbox"/> TRQ 0.01 to 10.00s	Y	Y	Y	Y
E30	Frequency arrival detection width (Detection width)	<input type="checkbox"/> V/f <input type="checkbox"/> PGV/f <input type="checkbox"/> SLV <input type="checkbox"/> PGV <input type="checkbox"/> PM SLV <input type="checkbox"/> PM PGV <input type="checkbox"/> TRQ 0.0 to 10.0Hz	Y	Y	Y	Y
E31	Frequency (operation level) detection 1	<input type="checkbox"/> V/f <input type="checkbox"/> PGV/f <input type="checkbox"/> SLV <input type="checkbox"/> PGV <input type="checkbox"/> PM SLV <input type="checkbox"/> PM PGV <input type="checkbox"/> TRQ 0.0 to 599.0Hz	Y	Y	Y	Y
E32	(Hysteresis width)		Y	Y	Y	Y
E34	Overload early warning/Current detection (operation level)	<input type="checkbox"/> V/f <input type="checkbox"/> PGV/f <input type="checkbox"/> SLV <input type="checkbox"/> PGV <input type="checkbox"/> PM SLV <input type="checkbox"/> PM PGV <input type="checkbox"/> TRQ 0.00 (Disable), 1 to 200% of inverter rated current (Inverter rated current dependent on F80)	Y	Y	Y	Y1 Y2
E35		0.01 to 600.00s	Y	Y	Y	Y
E36	Frequency detection 2 (Timer)	<input type="checkbox"/> V/f <input type="checkbox"/> PGV/f <input type="checkbox"/> SLV <input type="checkbox"/> PGV <input type="checkbox"/> PM SLV <input type="checkbox"/> PM PGV <input type="checkbox"/> TRQ 0.0 to 599.0Hz	Y	Y	Y	Y
E37	Current detection 2/Low current detection (Timer)	Same as E34	Y	Y	Y	Y1 Y2
E38	(Timer)	Same as E35	Y	Y	Y	Y
E39	Constant rate of feeding coefficient 1/ Speed display auxiliary coefficient 1	<input type="checkbox"/> V/f <input type="checkbox"/> PGV/f <input type="checkbox"/> SLV <input type="checkbox"/> PGV <input type="checkbox"/> PM SLV <input type="checkbox"/> PM PGV <input type="checkbox"/> TRQ 0.000 to 9999	Y	Y	Y	Y
E42	LED display filter	<input type="checkbox"/> V/f <input type="checkbox"/> PGV/f <input type="checkbox"/> SLV <input type="checkbox"/> PGV <input type="checkbox"/> PM SLV <input type="checkbox"/> PM PGV <input type="checkbox"/> TRQ 0.0 to 5.0s	Y	Y	Y	Y
E43	LED monitor (display selection)	<input type="checkbox"/> V/f <input type="checkbox"/> PGV/f <input type="checkbox"/> SLV <input type="checkbox"/> PGV <input type="checkbox"/> PM SLV <input type="checkbox"/> PM PGV <input type="checkbox"/> TRQ 0: Speed monitor (Selectable with E48) 3: Output current 4: Output voltage when alarm occurred 8: Calculated motor output torque when alarm occurred 9: Power consumption 10: PID process command 12: PID feedback value 13: Timer value 14: PID output 15: Load factor 16: Motor output 17: Analog signal input monitor 21: Current position 22: Positioning deviation 23: Torque current (%) 24: Magnetic flux command(%) 25: Input watt-hour 28: Stop target position 29: PID deviation 30: Torque bias 32: Customizable logic output	Y	N	Y	Y
E44	(Display when stopped)	0: Specified value 1: Output value	Y	N	Y	Y
E48	LED monitor details (Speed monitor selection)	<input type="checkbox"/> V/f <input type="checkbox"/> PGV/f <input type="checkbox"/> SLV <input type="checkbox"/> PGV <input type="checkbox"/> PM SLV <input type="checkbox"/> PM PGV <input type="checkbox"/> TRQ 0: Output frequency 1 (before slip compensation) 1: Output frequency 2 (after slip compensation) 2: Set frequency 3: Motor speed 4: Feed speed 5: Line speed 6: Constant feeding rate time 7: Speed (%)	Y	N	Y	Y
E49	Torque Command Monitor (Polarity selection)	<input type="checkbox"/> V/f <input type="checkbox"/> PGV/f <input type="checkbox"/> SLV <input type="checkbox"/> PGV <input type="checkbox"/> PM SLV <input type="checkbox"/> PM PGV <input type="checkbox"/> TRQ 0: Torque polarity 1: Plus for driving, Minus for braking	Y	Y	Y	Y
E50	Display coefficient for speed monitor	<input type="checkbox"/> V/f <input type="checkbox"/> PGV/f <input type="checkbox"/> SLV <input type="checkbox"/> PGV <input type="checkbox"/> PM SLV <input type="checkbox"/> PM PGV <input type="checkbox"/> TRQ 0.01 to 600.00	Y	Y	Y	Y
E51	Display coefficient for "Input watt-hour data"	<input type="checkbox"/> V/f <input type="checkbox"/> PGV/f <input type="checkbox"/> SLV <input type="checkbox"/> PGV <input type="checkbox"/> PM SLV <input type="checkbox"/> PM PGV <input type="checkbox"/> TRQ 0.000 (Cancel/Reset), 0.001 to 9999	Y	Y	Y	Y
E52	Keypad menu selection	<input type="checkbox"/> V/f <input type="checkbox"/> PGV/f <input type="checkbox"/> SLV <input type="checkbox"/> PGV <input type="checkbox"/> PM SLV <input type="checkbox"/> PM PGV <input type="checkbox"/> TRQ 0: Function code data setting mode (Menu 0, Menu 1, and Menu 7) 1: Function code data check mode (Menu 2 and Menu 7) 2: Full-menu mode	Y	Y	Y	Y
E54	Frequency detection 3 (Level)	<input type="checkbox"/> V/f <input type="checkbox"/> PGV/f <input type="checkbox"/> SLV <input type="checkbox"/> PGV <input type="checkbox"/> PM SLV <input type="checkbox"/> PM PGV <input type="checkbox"/> TRQ 0.0 to 599.0Hz	Y	Y	Y	Y
E55	Current detection 3 (Level)	Same as E34	Y	Y	Y	Y1 Y2
E56		Same as E35	Y	Y	Y	Y

*3 The rated current of the motor is set. For details, refer to the FRENIC-Ace (E3) User's Manual.

E codes : Extension Terminal Functions (terminal functions)

Function code	Name	Control method and Data setting range	Basic Type, EMC Filter Built-in type	Ethernet built-in Type	Change when running	Data copying
E57	Integral power pulse output unit	<p>V/f PGV/f SLV PGV PM SLV PM PGV TRQ</p> <p>0: Pulse output every 0.1 kWh 1: Pulse output every 1 kWh 2: Pulse output every 10 kWh 3: Pulse output every 100 kWh 4: Pulse output every 1000 kWh</p>	Y	Y	Y	Y
E61	Terminal [12] (extended function)	<p>V/f PGV/f SLV PGV PM SLV PM PGV TRQ</p>	Y	Y	N	Y
E62	Terminal [C1] (C1 function) (extended function)	<p>0: No extension function assignment 1: Auxiliary frequency setting 1 2: Auxiliary frequency setting 2</p>	Y	Y	N	Y
E63	Terminal [V2] (extended function)	<p>3: PID command 1 5: PID Dfeedback value 6: Ratio setting 7: Analog torque limiter A 8: Analog torque limit value B 9: Torque bias 10: Torque command 11: Torque current command 12: Acceleration/deceleration time ratio setting 13: Upper limit frequency 14: Lower limit frequency 15: Auxiliary frequency setting 3 16: Auxiliary frequency setting 4 17: Speed limit for forward rotation (FWD) 18: Speed limit for reverse rotation (REV) 20: Analog signal input monitor</p>	Y	Y	N	Y
E64	Saving of digital reference frequency	<p>V/f PGV/f SLV PGV PM SLV PM PGV TRQ</p> <p>0: Auto saving (main power is turned off) 1: Save by turning  key ON</p>	Y	Y	Y	Y
E65	Reference loss detection (Continuous running frequency)	<p>V/f PGV/f SLV PGV PM SLV PM PGV TRQ</p> <p>0: Stop deceleration 20 to 120%, 999: Cancel</p>	Y	Y	Y	Y
E70	Shift key (Function selection)	Table 1 Refer to E70 in the control input terminal setting table.	Y	N	N	Y
E71	M-LED indicator (Function selection)	Table 2 Refer to E71 in the control input terminal setting table.	Y	N	N	Y
E76	DC link bus low-voltage detection level	<p>V/f PGV/f SLV PGV PM SLV PM PGV TRQ</p> <p>200 to 400 V (200V series) 400 to 800 V (400V series)</p>	Y	Y	Y	Y2
E78	Torque detection 1 (Level)	<p>V/f PGV/f SLV PGV PM SLV PM PGV TRQ</p> <p>0 to 300%</p>	Y	Y	Y	Y
E79	(Timer)	0.01 to 600.00s	Y	Y	Y	Y
E80	Torque detection 2/ low torque detection (Level)	Same as E78	Y	Y	Y	Y
E81	(Timer)	Same as E79	Y	Y	Y	Y
E98	Terminal [FWD] (Function selection)	Table 1 Refer to E98 and E99 in the control input terminal setting table.	Y	Y	N	Y
E99	Terminal [REV] (Function selection)		Y	Y	N	Y

Features

Main application examples

Model variations

Type number nomenclature

Standard specifications

Common specifications

Terminal specifications

Basic wiring diagram

External dimensions

Keypad





Function codes

Options

Product warranty

Function Codes

C codes :Control Functions of Frequency (Control function)

Function code	Name	Control method and Data setting range	Basic Type, EMC Filter Built-in type	Ethernet built-in Type	Change when running	Data copying
C01	Jump frequency 1	<input type="checkbox"/> V/f <input type="checkbox"/> PGV/f <input type="checkbox"/> SLV <input type="checkbox"/> PGV <input type="checkbox"/> PM SLV <input type="checkbox"/> PM PGV <input type="checkbox"/> TRQ	Y	Y	Y	Y
C02	2	0.0 to 599.0Hz	Y	Y	Y	Y
C03	3		Y	Y	Y	Y
C04	(Skip width)	0.0 to 30.0Hz	Y	Y	Y	Y
C05	Multistep frequency 1	<input type="checkbox"/> V/f <input type="checkbox"/> PGV/f <input type="checkbox"/> SLV <input type="checkbox"/> PGV <input type="checkbox"/> PM SLV <input type="checkbox"/> PM PGV <input type="checkbox"/> TRQ	Y	Y	Y	Y
C06	2	0.00 to 599.00Hz	Y	Y	Y	Y
C07	3		Y	Y	Y	Y
C08	4		Y	Y	Y	Y
C09	5		Y	Y	Y	Y
C10	6		Y	Y	Y	Y
C11	7		Y	Y	Y	Y
C12	8		Y	Y	Y	Y
C13	9		Y	Y	Y	Y
C14	10		Y	Y	Y	Y
C15	11		Y	Y	Y	Y
C16	12		Y	Y	Y	Y
C17	13		Y	Y	Y	Y
C18	14		Y	Y	Y	Y
C19	15		Y	Y	Y	Y
C20	Jogging frequency	<input type="checkbox"/> V/f <input type="checkbox"/> PGV/f <input type="checkbox"/> SLV <input type="checkbox"/> PGV <input type="checkbox"/> PM SLV <input type="checkbox"/> PM PGV <input type="checkbox"/> TRQ 0.00 to 599.00Hz	Y	Y	Y	Y
C21	Pattern operation / timed operation (Operation selection)	<input type="checkbox"/> V/f <input type="checkbox"/> PGV/f <input type="checkbox"/> SLV <input type="checkbox"/> PGV <input type="checkbox"/> PM SLV <input type="checkbox"/> PM PGV <input type="checkbox"/> TRQ [Basic type / EMC filter built-in type] 0: cycle operation 1: Repetition operation 2: Constant speed operation after 1 cycle operation 3: Timed operation [Ethernet built-in type] 0: cycle operation 1: Repetition operation 2: Constant speed operation after 1 cycle operation	Y	Y	N	Y
C22	(Stage 1)		Y	Y	Y	Y
C23	(Stage 2)	Special setting: Press the key 3  times.	Y	Y	Y	Y
C24	(Stage 3)	1st: Set run time 0.0 to 6000 s and press the  key.	Y	Y	Y	Y
C25	(Stage 4)	2nd: Set rotational direction F (forward) or r (reverse) and press the  key.	Y	Y	Y	Y
C26	(Stage 5)	3rd: Set acceleration/deceleration time 1 to 4 and press the  key.	Y	Y	Y	Y
C27	(Stage 6)		Y	Y	Y	Y
C28	(Stage 7)		Y	Y	Y	Y
C30	Frequency setting 2	Same as F01	Y	Y	N	Y
C31	Analog input adjustment (Terminal [12]) (Offset)	<input type="checkbox"/> V/f <input type="checkbox"/> PGV/f <input type="checkbox"/> SLV <input type="checkbox"/> PGV <input type="checkbox"/> PM SLV <input type="checkbox"/> PM PGV <input type="checkbox"/> TRQ -5.0 to 5.0%	Y	Y	Y*	Y
C32	(Gain)	0.00 to 400.00%	Y	Y	Y*	Y
C33	(Filter)	0.00 to 5.00s	Y	Y	Y	Y
C34	(Gain base point)	0.00 to 100.00%	Y	Y	Y*	Y
C35	(polarity selection)	0: Bipolar 1: Unipolar	Y	Y	N	Y
C36	Analog input adjustment (Terminal [C1]) (Offset)	Same as C31	Y	Y	Y*	Y
C37	(C1 function) (Gain)	Same as C32	Y	Y	Y*	Y
C38	(Filter)	Same as C33	Y	Y	Y	Y
C39	(Gain base point)	Same as C34	Y	Y	Y*	Y
C40	(polarity selection)	0: 4 to 20 mA Unipolar 1: 0 to 20 mA Unipolar 10: 4 to 20 mA Bipolar 11: 0 to 20 mA Bipolar	Y	Y	N	Y
C41	Analog input adjustment (Terminal [C1]) (Offset)	Same as C31	Y	Y	Y*	Y
C42	(V2 function) (Gain)	Same as C32	Y	Y	Y*	Y
C43	(Filter)	Same as C33	Y	Y	Y	Y
C44	(Gain base point)	Same as C34	Y	Y	Y*	Y
C45	(polarity selection)	Same as C35	Y	Y	N	Y
C50	Bias (for frequency setting 1) (Bias base point)	<input type="checkbox"/> V/f <input type="checkbox"/> PGV/f <input type="checkbox"/> SLV <input type="checkbox"/> PGV <input type="checkbox"/> PM SLV <input type="checkbox"/> PM PGV <input type="checkbox"/> TRQ 0.00 to 100.00%	Y	Y	Y*	Y

Function code	Name	Control method and Data setting range	Basic Type, EMC Filter Built-in type	Ethernet built-in Type	Change when running	Data copying
C51	Bias (PID command 1) (bias value)	<input type="checkbox"/> V/f <input type="checkbox"/> PGV/f <input type="checkbox"/> SLV <input type="checkbox"/> PGV <input type="checkbox"/> PM SLV <input type="checkbox"/> PM PGV <input type="checkbox"/> TRQ -100.0 to 0.00 to 100.00%	Y	Y	Y*	Y
C52	(Bias base point)	0.00 to 100.00%	Y	Y	Y*	Y
C53	Selection of normal/ (Frequency setting 1)	<input type="checkbox"/> V/f <input type="checkbox"/> PGV/f <input type="checkbox"/> SLV <input type="checkbox"/> PGV <input type="checkbox"/> PM SLV <input type="checkbox"/> PM PGV <input type="checkbox"/> TRQ	Y	Y	Y	Y
C54	inverse operation (Frequency setting 2)	0: Normal 1: Inverse	Y	Y	Y	Y
C55	Analog input adjustment (Terminal [12]) (Bias)	<input type="checkbox"/> V/f <input type="checkbox"/> PGV/f <input type="checkbox"/> SLV <input type="checkbox"/> PGV <input type="checkbox"/> PM SLV <input type="checkbox"/> PM PGV <input type="checkbox"/> TRQ -200.0 to 0.00 to 200.00%	Y	Y	Y*	Y
C56	(Bias base point)	0.00 to 100.00%	Y	Y	Y*	Y
C58	(Display unit)	1: No unit [Flow] [Pressure] [Distance] 2: % 20: m ³ /s 40: Pa 65: Nm 4: r/min 21: m ³ /min 41: kPa 66: lb Ft 7: kW 22: m ³ /h 42: MPa 70: mm 8: HP 23: L/s 43: mbar 71: cm 10: mm/s 24: L/min 44: bar 72: m 11: mm/m 25: L/h 45: mmHg 73: km 12: mm/h 26: GPS 46: PSI 74: in 13: m/s 27: GPM 47: mWG 75: Ft 14: m/min 28: GPH 48: inWG 76: Yd 15: m/h 29: CFS 49: inHg 77: mi 16: FPS 30: CFM 50: WC 17: FPM 31: CFH 51: Ft WG [Concentration] 18: FPH 32: kg/s 52: ATM 80: ppm 19: SPM 33: kg/m 34: kg/h [Temperature] [Others] 35: lb/s 60: K 90: m ³ 36: lb/m 61: °C 91: L 37: lb/h 62: °F 92: GAL 38: AF/Y 93: OZ	Y	Y	Y	Y
C59	(maximum scale)	-999.0 to 0.00 to 9990.0	Y	Y	N	Y
C60	(minimum scale)	-999.0 to 0.00 to 9990.0	Y	Y	N	Y
C61	Analog input adjustment (Terminal [C1]) (Bias)	<input type="checkbox"/> V/f <input type="checkbox"/> PGV/f <input type="checkbox"/> SLV <input type="checkbox"/> PGV <input type="checkbox"/> PM SLV <input type="checkbox"/> PM PGV <input type="checkbox"/> TRQ -200.0 to 0.00 to 200.00%	Y	Y	Y*	Y
C62	(C1 function) (Bias base point)	0.00 to 100.00%	Y	Y	Y*	Y
C64	(Display unit)	Same as C58	Y	Y	Y	Y
C65	(maximum scale)	-999.0 to 0.00 to 9990.0	Y	Y	N	Y
C66	(minimum scale)	-999.0 to 0.00 to 9990.0	Y	Y	N	Y
C67	Analog input adjustment (Terminal [C1]) (Bias)	<input type="checkbox"/> V/f <input type="checkbox"/> PGV/f <input type="checkbox"/> SLV <input type="checkbox"/> PGV <input type="checkbox"/> PM SLV <input type="checkbox"/> PM PGV <input type="checkbox"/> TRQ -200.0 to 0.00 to 200.00%	Y	Y	Y*	Y
C68	(V2 function) (Bias base point)	0.00 to 100.00%	Y	Y	Y*	Y
C70	(Display unit)	Same as C58	Y	Y	Y	Y
C71	(maximum scale)	-999.0 to 0.00 to 9990.0	Y	Y	N	Y
C72	(minimum scale)	-999.0 to 0.00 to 9990.0	Y	Y	N	Y
C89	Frequency compensation 1 via communication (Numerator)	<input type="checkbox"/> V/f <input type="checkbox"/> PGV/f <input type="checkbox"/> SLV <input type="checkbox"/> PGV <input type="checkbox"/> PM SLV <input type="checkbox"/> PM PGV <input type="checkbox"/> TRQ -32768 to 32767	Y	Y	Y	Y
C90	Frequency compensation 2 via communication (Denominator)	(Keypad display is 8000 to 7FFF (in hexadecimal)) (Interpreted as 1 when the value is set to 0)	Y	Y	Y	Y
C94	Jump frequency 4	<input type="checkbox"/> V/f <input type="checkbox"/> PGV/f <input type="checkbox"/> SLV <input type="checkbox"/> PGV <input type="checkbox"/> PM SLV <input type="checkbox"/> PM PGV <input type="checkbox"/> TRQ	Y	Y	Y	Y
C95	5	0.0 to 599.0Hz	Y	Y	Y	Y
C96	6		Y	Y	Y	Y
C99	Digital setting frequency	<input type="checkbox"/> V/f <input type="checkbox"/> PGV/f <input type="checkbox"/> SLV <input type="checkbox"/> PGV <input type="checkbox"/> PM SLV <input type="checkbox"/> PM PGV <input type="checkbox"/> TRQ 0.00 to maximum output frequency (1 to 2)	Y	N	Y*	Y

This catalog covers only the function codes as follows:

F codes (Basic functions), E codes (Extension terminal functions), C codes (Control functions)

For the other function codes, refer to the "FRENIC-Ace User's Manual (24A7-E-0173)"

MEMO

A series of horizontal dashed lines for writing.

Options

Connection configuration

For main power input and inverter output

AC reactor
 [ACR□-□□□]
 When using a power supply with unstable voltage.

*1 If not using an R0, T0 terminal, connect a connector at this location.

Arrester
 [CN5□□□]
 Suppresses induced lightning surges from the power source to protect entire equipment connected to the power source.

Ferrite ring for reducing radio noise
 [ACL-40C, ACL-74C, F200160]
 Used to reduce radio noise. Suppressive effect to the frequency band is available by approximately 1MHz or more. This is appropriate as a simple measure against noise since it affects broad range in the frequency band.

EMC compliance filter
 [EFL-□□□□, FS□□, FN□□]
 Dedicated filter to comply with the European EMC Directive (Emission). Install the filter while referring to the details in the installation manual.

Power filter for output circuit
 [RNF□□□□-□□]
 This will become more effective in noise reduction if used together with the power filter for input circuit.

*2 If using an R0, T0 terminal, connect a connector at this location.

Filter capacitor for reducing radio noise
 [NFM□□□M315KPD□]
 Used to reduce radio noise. This is effective for the AM radio frequency band. *Do not use it on the inverter output side. [Made by Nippon Chemi-con]

Power filter for input circuit
 [RNF□□□□-□□]
 This filter can be used for the same purpose as the EMC compliance filter, but is not an EMC compliance.

Output circuit filter
 [OFL-□□□-4A]
 Connected to the output of an inverter to:
 • Suppress fluctuations of motor terminal voltage.
 • Prevent damages to the motor insulation due to surge voltage in 400V series inverter.
 *This filter is not limited by carrier frequency. Also, motor can be tuned while this option is installed.

External operation, measurement, and communication

- **Standard keypad** [TP-M3]
 - **Remote keypad** [TP-E2]
 - **Multi-function keypad with LCD** [TP-A2SW]
- Used to remotely control the inverter. However, an optional keypad relay adapter (CBAD-CP) is required.

Extension cable for remote control [CB-□□S]
 Cable used for remote control

PC loader for Windows Inverter support software
 This software is used to set the function codes of the inverter from a PC, to manage the data.

Relay adapter [CBAD-CP]
 This is a relay adapter to remotely control the unit with the keypad.

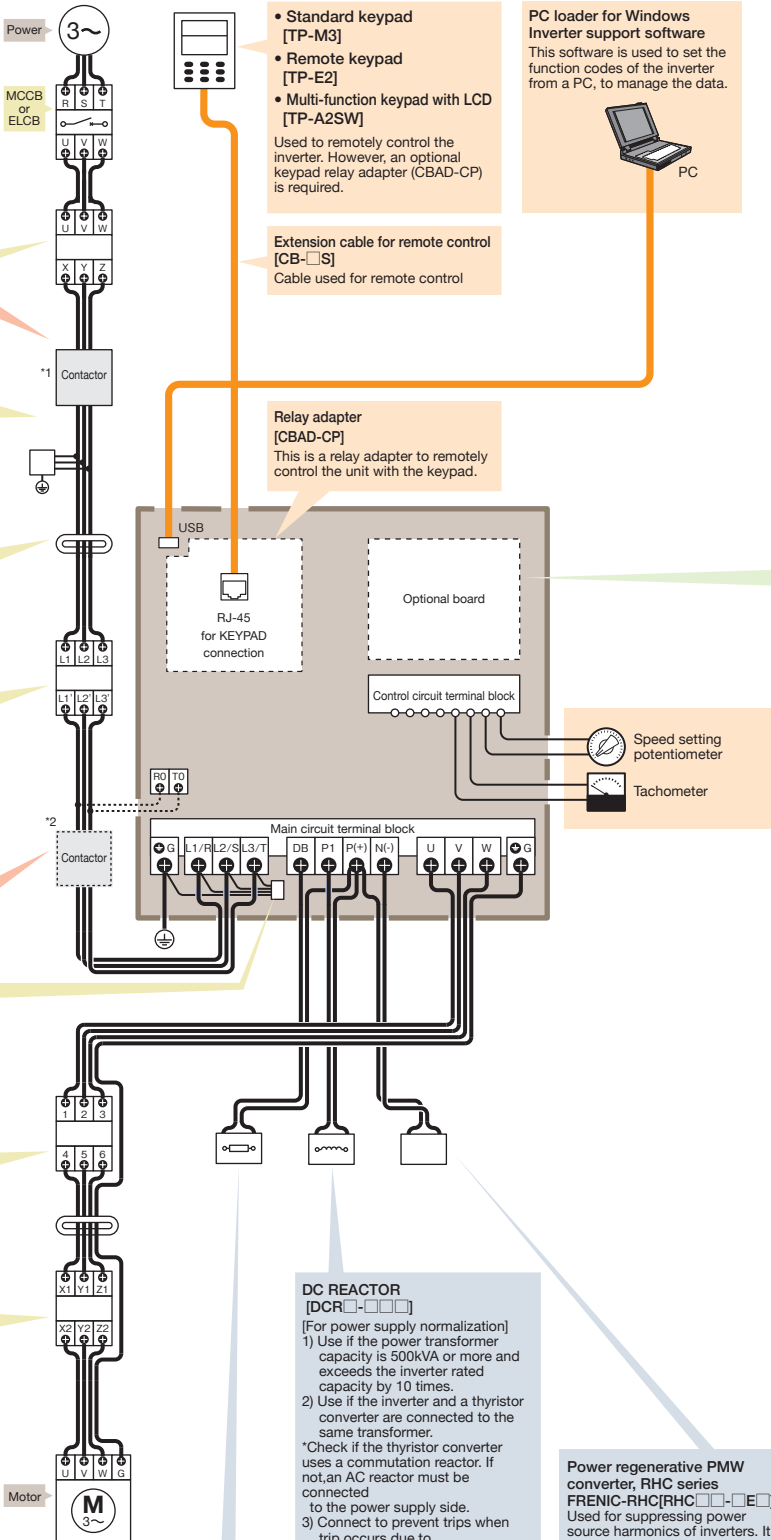

Braking resistor
 [DB□□-□□, DB□□-□□C]
 Increases braking capability for highly frequent stopping and large moment of inertia. When used together with a braking unit, connect this to the connection terminal of the braking unit.

DC REACTOR
 [DCR□-□□□]
 [For power supply normalization]
 1) Use if the power transformer capacity is 500kVA or more and exceeds the inverter rated capacity by 10 times.
 2) Use if the inverter and a thyristor converter are connected to the same transformer.
 *Check if the thyristor converter uses a commutation reactor. If not, an AC reactor must be connected to the power supply side.
 3) Connect to prevent trips when trip occurs due to opening/closing of the phase-advancing capacitor for the power supply lines.
 [For improving the input power-factor and reducing harmonics]
 •Used to reduce the input harmonic current (correcting power-factor)
 * For the drop effect, refer to the guideline appendix.

Power regenerative PMW converter, RHC series FRENIC-RHC
 [RHC□□-□□E□]
 Used for suppressing power source harmonics of inverters. It is also equipped with a power supply regenerative function to drastically increase braking capability and reduce energy consumption.
 * Use in combination with the RHC Series dedicated pressurization reactor, resistor, and capacitor.

Built-in option card

(1) Adapter for option cards Requires (OPC-CP-ADP)

■ **Control option cards**
 • **Digital I/O interface card** [OPC-DIO]
 Frequency setting by binary and BCD digital signals

• **Analog interface card** [OPC-AIO]
 Torque control by external analog signal

• **Relay output interface card** [OPC-CP-RY]

■ **Communication option cards**

- **Open bus cards**
 Data link between various open buses and inverters
- **Multiprotocol Ethernet communication card** [OPC-CP-ETM]
- **ProfiBus-DP communication card** [OPC-PDP3]
- **DeviceNet communication card** [OPC-DEV]
- **CANopen communication card** [OPC-COP2]
- **CC-Link communication card** [OPC-CCL]

(2) Remove the control board of the main unit and install the following option cards

■ **Control option cards**
 • **PG interface card** [OPC-CP-PG, OPC-CP-PG3]
 Performs PG vector control via feedback signals from the encoder

■ **Communication option cards**
 • **RS-485 communication card** [OPC-CP-RS]

■ **Control terminal block option** [OPC-E2-TB1]
 Capable of being changed to stick terminal/screw terminal.

Adapter for option cards [OPC-CP-ADP]
 This is a dedicated adapter for mounting various option cards.

* Not available for E3N type

DIN rail mounting bases [RMA-E2-□□]
 This is a base for mounting the inverter on a DIN rail (35mm width).

Filter unit [IFL-□□□U-□]
 Effectively reduces harmonics and noise when used in combination with an inverter. Comes with a built-in DC reactor, zero-phase reactor, and capacitive filter that effectively reduces noise.

External cooling attachment [PB-F1-□□]
 This attachment is used to move the inverter's cooling fins to a position that is outside the board.

Peripheral and structure options

Features

Main application examples

Model variations

Type number nomenclature

Standard specifications

Common specifications

Terminal specifications

Basic wiring diagram

External dimensions

Keypad

Function codes

Options

Product warranty

Options

Remote keypad [TP-E2]

The FRENIC loader and inverter can be connected via USB. When combined with the FRENIC loader, various types of information on the inverter can be stored in the memory of the touch panel.

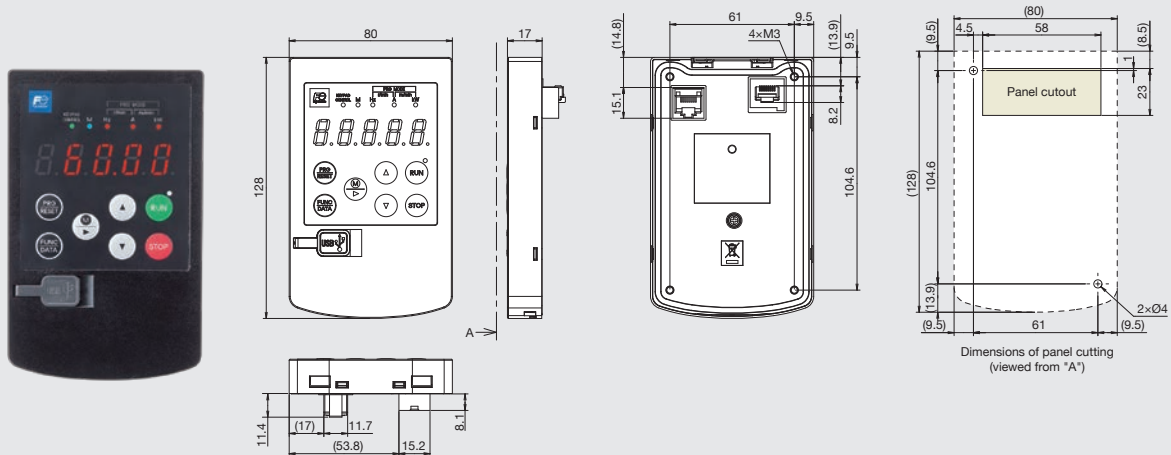

Note 1) The keypad cannot be attached directly to the main unit of the FRENIC-Ace.
 Note 2) Connect it using the optional keypad relay adapter (CBAD-CP) and LAN cable (straight) with RJ-45 connector.
 Note 3) Cannot be installed in Ethernet built-in type.

Multi-function keypad [TP-A2SW]

- Equipped with a highly visible LCD.
- Supports a total of 20 languages, including Japanese hiragana, katakana and kanji.
- Parameter changes and maintenance can be performed remotely using a mobile device built-in bluetooth.



Item	Specification	Remarks
Supported languages	Supports a total of 20 languages, including Japanese, English and Chinese.	
Copy function	Three sets can be stored.	
USB port	Type: mini B	FRENIC Loader for Windows 10 or later
Wireless communication network	Bluetooth Ver.5.0	FRENIC Mobile Loader for Android 8 or later
micro SD card*	SDHC standards (max 32GB)	Trace back function
Battery*	CR2032	Real-time clock function
Extension cable	ANSI/TIA/EIA568A Category 5 (10BASE-T/100BASE-TX)	Option type: CB-□S
Connector for keypad	RJ-45	
Enclosure	Outside cabinet: IP55, inverter back side: IP20	
Approx. weight	135 g	

*SD card not included.

Note 1) The keypad cannot be attached directly to the main unit of the FRENIC-Ace.
 Note 2) Connect it using the optional keypad relay adapter (CBAD-CP) and LAN cable (straight) with RJ-45 connector.
 Note 3) Cannot be installed in Ethernet built-in type.

Extension cable for remote control [CB-□S]

This straight cable is used to connect the RJ-45 connector of the inverter body to the keypad, USB-RS485 converter, etc.
 Available in three lengths (1, 3, 5m).



- Cable

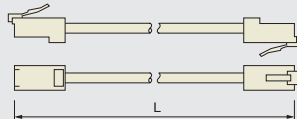

Type	CB-5S	CB-3S	CB-1S
Length [m]	5	3	1

Adapter for Keypad panel [CBAD-CP]

This is a relay adapter to remotely control the unit with the standard keypad or remote keypad (optional). This adapter is a bundled product consisting of a relay connector for the inverter and a rear mounting adapter for the panel surface.

*Cannot be installed in Ethernet built-in type.

Connection accessories



Mounting adapter



Connection accessories

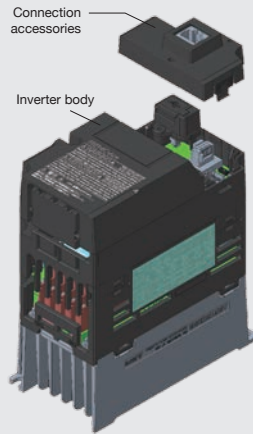

Mounting adapter

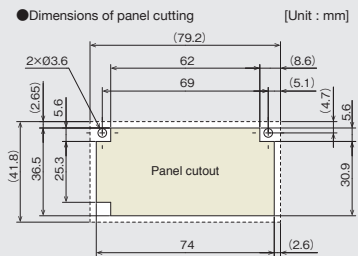
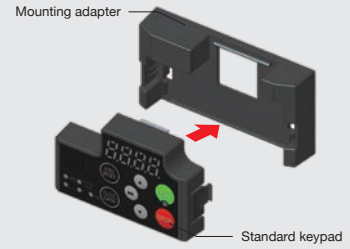

Mounting adapter [OPC-CP-ADP]

This adapter is required when installing the following options.

*Cannot be installed in Ethernet built-in type.

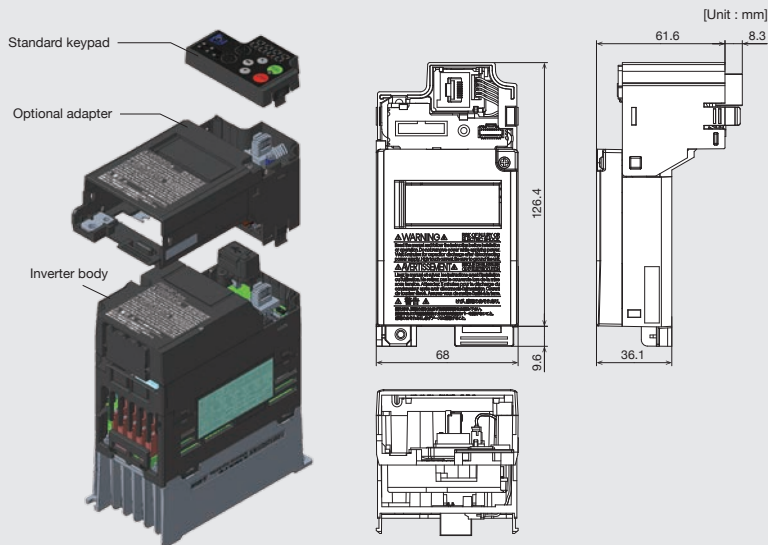

Supported option cards

	Name	Type
I/O interface	Digital I/O interface card	OPC-DIO
	Analog interface card	OPC-AIO
	Relay output interface card	OPC-CP-RY
Communication	Multiprotocol Ethernet communication card	OPC-CP-ETM
	Profibus-DP communication card	OPC-PDP3
	DeviceNet communication card	OPC-DEV
	CANopen communication card	OPC-COP2
	CC-Link communication card	OPC-CCL

Depth (D) dimension when the optional adapter is mounted

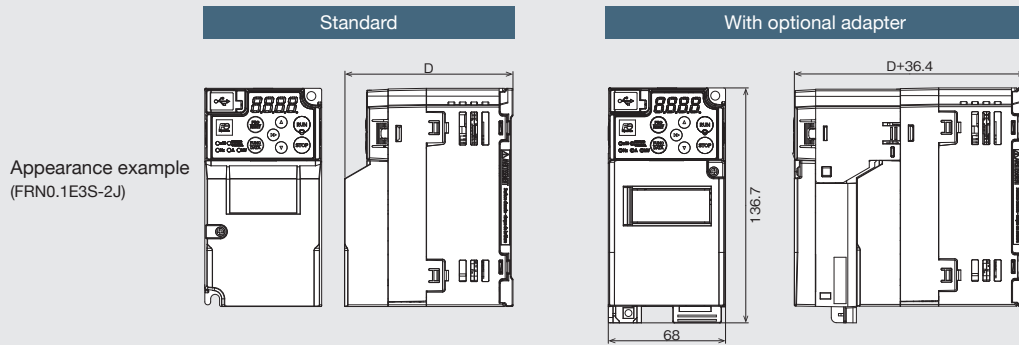

Basic type

3-phase 200V series		
Type	Standard	With optional adapter
	D [mm]	D+36.4 [mm]
FRN0001E3S-2G	98	134.4
FRN0002E3S-2G		
FRN0004E3S-2G		
FRN0006E3S-2G	113	149.4
FRN0010E3S-2G	145	181.4
FRN0012E3S-2G	156	192.4
FRN0020E3S-2G		
FRN0030E3S-2G		
FRN0040E3S-2G	171	207.4
FRN0056E3S-2G	203	239.4
FRN0069E3S-2G		
FRN0088E3S-2G		
FRN0115E3S-2G		

3-phase 400V series		
Type	Standard	With optional adapter
	D [mm]	D+36.4 [mm]
FRN0002E3S-4G	132	168.4
FRN0004E3S-4G		
FRN0006E3S-4G		
FRN0007E3S-4G	156	192.4
FRN0012E3S-4G		
FRN0022E3S-4G		
FRN0029E3S-4G	171	207.4
FRN0037E3S-4G	203	239.4
FRN0044E3S-4G		
FRN0059E3S-4G		
FRN0072E3S-4G		

1-phase 200V series		
Type	Standard	With optional adapter
	D [mm]	D+36.4 [mm]
FRN0001E3S-7G	98	134.4
FRN0002E3S-7G		
FRN0004E3S-7G	120	156.4
FRN0006E3S-7G	165	201.4
FRN0010E3S-7G	166	202.4
FRN0012E3S-7G	156	192.4

EMC filter built-in type

3-phase 400V series		
Type	Standard	With optional adapter
	D [mm]	D+36.4 [mm]
FRN0002E3S-4G	132	168.4
FRN0004E3S-4G		
FRN0006E3S-4G		
FRN0007E3S-4G	156	192.4
FRN0012E3S-4G		
FRN0022E3S-4G		
FRN0029E3S-4G	171	207.4
FRN0037E3S-4G	203	239.4
FRN0044E3S-4G		
FRN0059E3S-4G		
FRN0072E3S-4G		

1-phase 200V series		
Type	Standard	With optional adapter
	D [mm]	D+36.4 [mm]
FRN0001E3S-7G	98	134.4
FRN0002E3S-7G		
FRN0004E3S-7G	120	156.4
FRN0006E3S-7G	165	201.4
FRN0010E3S-7G	166	202.4
FRN0012E3S-7G	156	192.4

DIN rail mounting bases (RMA-E2-□□)

This is an option for mounting the inverter on a DIN rail (35mm width).

● RMA-E2-0.75

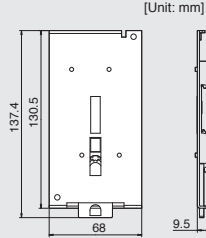

● RMA-E2-2.2

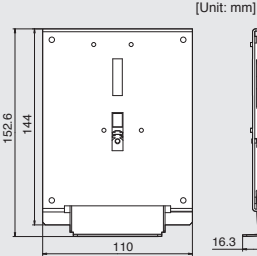

● RMA-E2-3.7

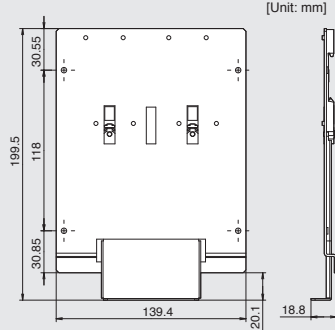

		RMA-E2-0.75	RMA-E2-2.2	RMA-E2-3.7
Basic type (E3S)	3-phase 200 V series	FRN0001E3S-2G to FRN0006E3S-2G	FRN0010E3S-2G to FRN0012E3S-2G	FRN0020E3S-2G
	3-phase 400 V series	—	FRN0002E3S-4G to FRN0007E3S-4G	FRN0012E3S-4G
	1-phase 200 V series	FRN0001E3S-7G to FRN0006E3S-7G	FRN0010E3S-7G	FRN0012E3S-7G
EMC filter built-in type (E3E)	3-phase 400 V series	—	FRN0002E3E-4G to FRN0004E3E-4G	FRN0006E3E-4G to FRN0012E3E-4G
	1-phase 200 V series	FRN0001E3E-7G to FRN0004E3E-7G	FRN0005E3E-7G	FRN0008E3E-7G to FRN0011E3E-7G
Ethernet built-in type (E3N)	3-phase 200 V series	FRN0001E3N-2G to FRN0006E3N-2G	FRN0010E3N-2G to FRN0012E3N-2G	FRN0020E3N-2G
	3-phase 400 V series	—	FRN0002E3N-4G to FRN0007E3N-4G	FRN0012E3N-4G
	1-phase 200 V series	FRN0001E3N-7G to FRN0006E3N-7G	FRN0010E3N-7G	FRN0012E3N-7G

External cooling fan attachment [PB-□1-□□]

This attachment is used to move the inverter's cooling fins to a position that is outside the board.

● PB-E1-7.5

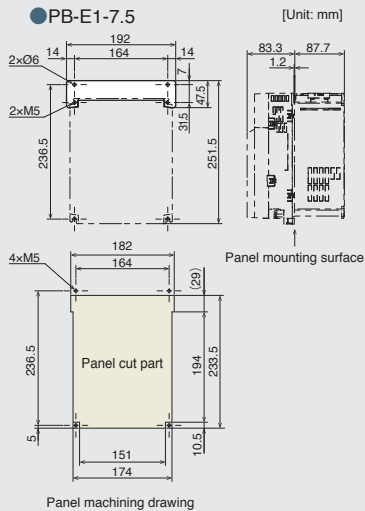

● PB-F1-15

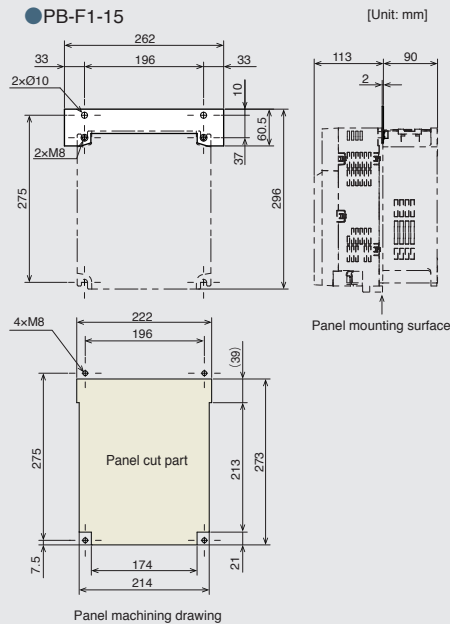

● PB-F1-30

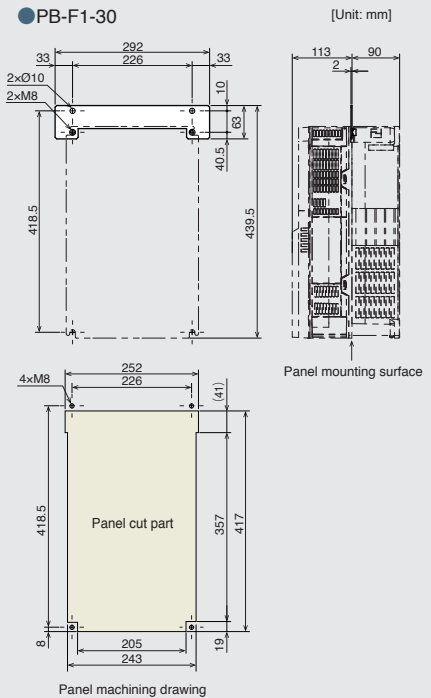

PB-E1-7.5	PB-F1-15	PB-F1-30
FRN0030E3S-2G, FRN0040E3S-2G FRN0022E3S-4G, FRN0029E3S-4G FRN0030E3N-2G, FRN0040E3N-2G FRN0022E3N-4G, FRN0029E3N-4G	FRN0056E3S-2G, FRN0069E3S-2G FRN0037E3S-4G, FRN0044E3S-4G FRN0056E3N-2G, FRN0069E3N-2G FRN0037E3N-4G, FRN0044E3N-4G	FRN0088E3S-2G, FRN0115E3S-2G FRN0059E3S-4G, FRN0072E3S-4G FRN0088E3N-2G, FRN0115E3N-2G FRN0059E3N-4G, FRN0072E3N-4G

Built-in option card

Item	Type	Specification
(1) Adapter mounting type option cards By using the adapter for mounting options (OPC-CP-ADP), one of the following options can be mounted.		
Digital I/O interface card	OPC-DIO	Provides additional digital I/O. <ul style="list-style-type: none"> • Frequency settings can be made using binary (8, 12 bit) and BCD codes. • Monitoring is available using binary codes (8 bit). • Capable of extending general-purpose input terminals. (I1 to I13) • Capable of extending general-purpose output terminals. (O1 to O8)
Analog interface card	OPC-AIO	Enables torque limit value, frequency setting, and ratio tuning setting via analog input. Enables monitoring of inverter output frequency, current, torque, etc. in analog quantities. <ul style="list-style-type: none"> • Analog input <ul style="list-style-type: none"> • Analog voltage input: 1 (0 to ± 10 V) • Analog current input: 1 (4 to 20 mA or 0 to 20 mA) • Analog output <ul style="list-style-type: none"> • Analog voltage output: 1 (0 to ± 10 V) • Analog current output: 1 (4 to 20 mA)
Relay output interface card	OPC-CP-RY	Supports up to three additional relay outputs (1C contact). <ul style="list-style-type: none"> • 250 V AC 0.3 A $\cos \phi = 0.3$ or 48 V DC 0.5 A (resistive load)
Multi-protocol Ethernet communication card	OPC-CP-ETM	Connects to the master device via Ethernet communication (EtherNet/IP, PROFINET, Modbus TCP), enabling setting of operation commands and frequency commands, and setting and checking of function codes. <ul style="list-style-type: none"> • Connector type: RJ-45 shielded • Ethernet cable: CAT5e or higher UTP or STP cable • Physical layer type: IEEE 802.3 • Number of ports • Communication speed: 10Mbps/100Mbps (automatic detection)
PROFIBUS-DP communication card	OPC-PDP3	Operation and frequency commands can be set from PROFIBUS-DP master, enabling monitoring of operation status and changing/checking of all function codes. <ul style="list-style-type: none"> • Communication speed: 9.6 kbps to 12 Mbps • Transmission distance: Up to 1,200m • Connector: 2 x 6-pole terminal block
DeviceNet communication card	OPC-DEV	Operation and frequency commands can be set from DeviceNet master, enabling monitoring of operation status and changing/checking of all function codes. <ul style="list-style-type: none"> • No. of connected nodes: Up to 64 (including master) • MAC ID: 0 to 63 • Insulation: 500 VDC (photocoupler insulation) • Communication speed: 500 kbps/250 kbps/125 kbps • Network power consumption: Up to 80 mA 24 VDC
CANopen communication card	OPC-COP2	Operation and frequency commands can be set from CANopen master (PC, PLC, etc.), as well as setting/checking of all function codes. <ul style="list-style-type: none"> • No. of connected nodes: Up to 127 • Communication speed: 20 kbps, 50 kbps, 125 kbps, 250 kbps, 500 kbps, 800 kbps, 1 Mbps • Transmission distance: Up to 2,500 m
CC-Link communication card	OPC-CCL	When connecting to a CC-Link master unit, it supports a communication speed of up to 10 Mbps and a total length of up to 1,200 m. <ul style="list-style-type: none"> • No. of connected units: 42 • Communication method: CC-Link Ver1.10 and Ver2.0 • Communication speed: 156 kbps or faster
(2) Terminal block type option cards The terminal block board of the main unit can be removed and one of the following option cards can be installed.		
PG interface card	OPC-CP-PG	Comes with a two-system pulse input circuit, enabling speed control, simple position control, and synchronous operation. <ul style="list-style-type: none"> • Application: Speed control (vector control with sensor) pulse train input • Specifications: 20 to 3600 P/R A, B, Z phases (incremental) Open collector/complementary system • PG power supply: +5 Vdc $\pm 10\%$ / 200 mA or less
	OPC-CP-PG3	Comes with a two-system pulse input circuit, enabling speed control, simple position control, and synchronous operation. <ul style="list-style-type: none"> • Application: Speed control (vector control with sensor) pulse train input • Specifications: 20 to 3600 P/R A, B, Z phases (incremental) Open collector/complementary system • PG power supply: +12 Vdc $\pm 10\%$ / 80 mA or less or +15 Vdc $\pm 10\%$ / 60mA or less
RS485 communication card	OPC-CP-RS	By replacing the standard terminal block of Ace, it can be expanded to two RJ-45 connectors for RS485 communication, allowing for easy multi-drop connection.
Control terminal block option (screw type terminal block)	OPC-E2-TB1	Capable of being changed to stick terminal/screw terminal. Excluding EN terminal EN1/EN2, relay output 30 A/B/C. <ul style="list-style-type: none"> • Digital input FWD, REV, X1 to X5 • Digital output Y1, Y2 • Analog input <ul style="list-style-type: none"> 11 Analog I/O common 12 Setting voltage input 0 to ± 10 V DC 13 Variable resistor power supply • C1 current input 4 (0) to 20 mA DC or PTC thermistor input 0 to +10 V DC • Analog output <ul style="list-style-type: none"> FM 1 current output 4 (0) to 20 mA DC, voltage output 0 to ± 10 V DC, or pulse output FM 2 current output 4 (0) to 20 mA DC, or voltage output • RS 485 communication DX+, DX-, SD

Note) The type with built-in Ethernet cannot be mounted with option cards.
Simultaneous mounting is possible with (1) and (2).

Breaking resistor

[Standard specifications]

[DB□□ - □]

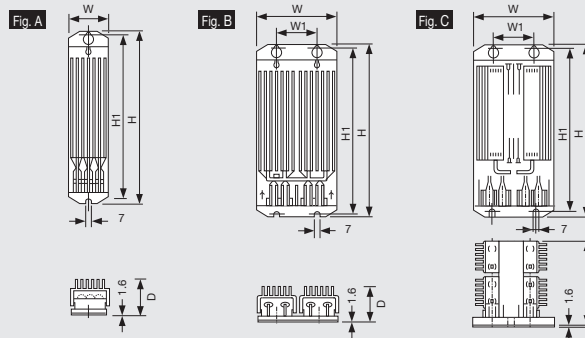
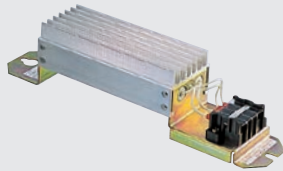

Voltage	Type	Fig	Dimensions [mm]					Approx. weight [kg]
			W	W1	H	H1	D	
3-phase 200V	DB0.75-2	A	68	-	310	295	67	1.3
	DB2.2-2		80	-	345	332	94	2
	DB3.7-2		80	-	345	332	94	2
	DB5.5-2	B	146	90	450	430	67.5	4.5
	DB7.5-2		160	90	390	370	90	5
	DB11-2	C	142	74	430	415	160	6.9
	DB15-2		142	74	430	415	160	6.9
	DB18.5-2		142	74	510	495	160	8.7
	DB22-2		142	74	510	495	160	8.7

Voltage	Type	Fig	Dimensions [mm]					Approx. weight [kg]
			W	W1	H	H1	D	
3-phase 400V	DB0.75-4	A	68	-	310	295	67	1.3
	DB2.2-4		68	-	470	455	67	2
	DB3.7-4		68	-	470	455	67	1.7
	DB5.5-4	B	146	74	470	455	67	4.5
	DB7.5-4		146	74	510	495	67	5
	DB11-4	C	142	74	430	415	160	6.9
	DB15-4		142	74	430	415	160	6.9
	DB18.5-4		142	74	510	495	160	8.7
	DB22-4		142	74	510	495	160	8.7

Breaking resistor

[10%EDSpec.]

[DB□□ - □C]

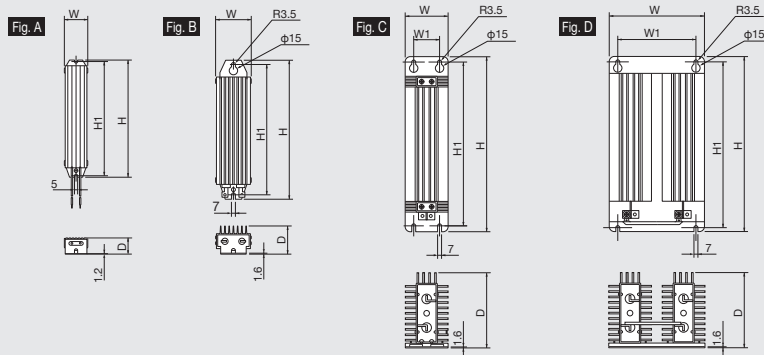

Type	Fig	Dimensions [mm]				
		W	W1	H	H1	D
DB0.75-2C/4C	A	43	-	221	215	30.5
DB2.2-2C/4C	B	67	-	188	172	55
DB3.7-2C/4C		67	-	328	312	55
DB5.5-2C/4C	B	80	-	378	362	78
DB7.5-2C/4C		80	-	418	402	78
DB11-2C/4C	C	80	50	460	440	140
DB15-2C/4C		80	50	580	560	140
DB22-2C/4C		180	144	400	383	145

Braking resistor [Compact type]

(TK80W120Ω, TK80W100Ω)

TK80W120Ω

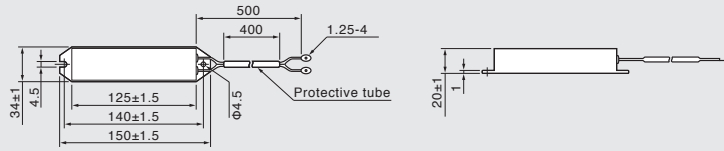

Power supply voltage	Type	TK80W120Ω								
200 V series	Resistance	Capacity [kW]	0.08							
		Resistance value [Ω]	120							
	Applicable inverter capacity [kW]*	0.1	0.2	0.4	0.75	1.5	2.2	3.7		
	Applicable motor output [kW]	0.1	0.2	0.4	0.75	1.5	2.2	3.7		
	Maximum braking torque [%]	150	150	150	130	100	65	45		
	Allowable braking characteristic	Allowable braking frequency [%]	25	25	15	5	5	5	5	
		Continuous allowable braking time	30sec	30sec	15sec	15sec	10sec	10sec	10sec	

(Note) This resistor is not applicable to 400 V series products.

*The 0.1 kW and 0.2 kW FRENIC-Mini Series does not support braking resistors. (However, the Mini unit comes with a DB terminal screw.)

TK80W100Ω

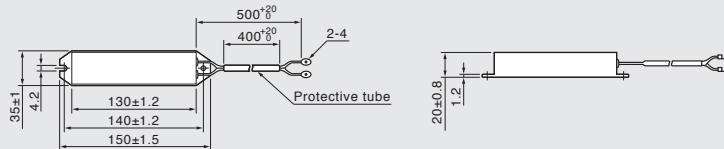

Power supply voltage	Type	TK80W100Ω								
200 V series	Resistance	Capacity [kW]	0.08							
		Resistance value [Ω]	100							
	Applicable inverter capacity [kW]*	0.1	0.2	0.4	0.75	1.5	2.2	3.7		
	Applicable motor output [kW]	0.1	0.2	0.4	0.75	1.5	2.2	3.7		
	Maximum braking torque [%]	150	150	150	120	80	50			
	Allowable braking characteristic	Allowable braking frequency [%]	30	30	15	10	5	4	4	
		Continuous allowable braking time	80sec	80sec	40sec	20sec	10sec	9sec	8sec	

(Note) This resistor is not applicable to 400 V series products.

*The 0.1 kW and 0.2 kW FRENIC-Mini Series does not support braking resistors. (However, the Mini unit comes with a DB terminal screw.)

AC Reactor [ACR□-□□□]

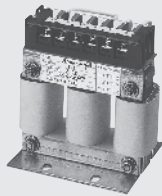

Fig.A

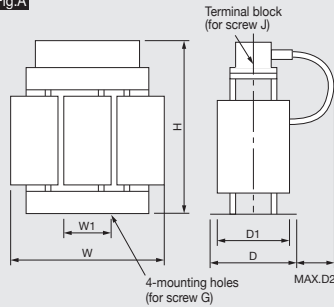
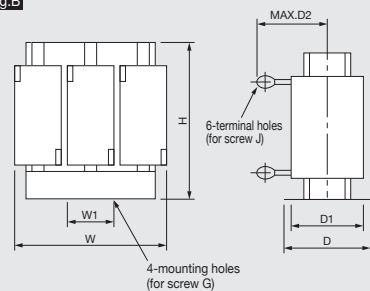

Fig.B



Voltage	Standard applicable motor kW(HP)	Inverter type				Reactor Type	Fig	Dimensions [mm]								Approx. weight [kg]
		ND	HD	HND	HHD			W	W1	D	D1	D2	G	H	J	
3-phase 400V	0.4(1/2)	—	—	—	FRN0002E3□-4G	ACR4-0.75A	B	120	90	65	106	M5 (6×10)	85	M4	1.1	
	0.75(1)	FRN0002E3□-4G	FRN0002E3□-4G	FRN0002E3□-4G	FRN0004E3□-4G	ACR4-1.5A										
	1.1(1.5)	—	FRN0004E3□-4G	FRN0004E3□-4G	—	ACR4-2.2A										
	1.5(2)	FRN0004E3□-4G	—	—	FRN0006E3□-4G	ACR4-3.7A										
	2.2(3)	FRN0006E3□-4G	FRN0006E3□-4G	FRN0006E3□-4G	FRN0007E3□-4G	ACR4-5.5A										
	3.0(4)	FRN0007E3□-4G	FRN0007E3□-4G	FRN0007E3□-4G	—	ACR4-7.5A										
	3.7(5)	—	—	—	FRN0012E3□-4G	ACR4-11A										
	5.5(7.5)	FRN0012E3□-4G	FRN0012E3□-4G	FRN0012E3□-4G	FRN0022E3□-4G	ACR4-15A										
	7.5(10)	—	FRN0022E3□-4G	FRN0022E3□-4G	FRN0029E3□-4G	ACR4-18.5A										
	11(15)	FRN0029E3□-4G	FRN0029E3□-4G	FRN0029E3□-4G	FRN0037E3□-4G	ACR4-22A										
	15(20)	FRN0037E3□-4G	FRN0037E3□-4G	FRN0037E3□-4G	FRN0044E3□-4G	ACR4-37										
	18.5(25)	FRN0044E3□-4G	FRN0044E3□-4G	FRN0044E3□-4G	FRN0059E3□-4G	—										
	22(30)	FRN0059E3□-4G	FRN0059E3□-4G	FRN0059E3□-4G	FRN0072E3□-4G	—										
	30(40)	FRN0072E3□-4G	FRN0072E3□-4G	FRN0072E3□-4G	—	—										
	37(50)	FRN0072E3□-4G	—	—	—	—										
	3-phase 200V	0.1(1/8)	—	—	—	FRN0001E3□-2G		ACR2-0.4A	A	120	90	65	20	M5 (6×10)	115	M4
0.2(1/4)		FRN0001E3□-2G	FRN0002E3□-2G	FRN0002E3□-2G	FRN0004E3□-2G	ACR2-0.75A										
0.4(1/2)		FRN0002E3□-2G	FRN0004E3□-2G	FRN0004E3□-2G	—	ACR2-1.5A										
0.75(1)		FRN0004E3□-2G	—	—	FRN0010E3□-2G	ACR2-2.2A										
1.1(1.5)		—	FRN0010E3□-2G	FRN0012E3□-2G	—	ACR2-3.7A										
1.5(2)		FRN0010E3□-2G	FRN0012E3□-2G	FRN0012E3□-2G	—	ACR2-5.5A										
2.2(3)		FRN0012E3□-2G	—	—	FRN0020E3□-2G	ACR2-7.5A										
3.0(4)		—	FRN0020E3□-2G	FRN0030E3□-2G	FRN0040E3□-2G	ACR2-11A										
3.7(5)		—	FRN0030E3□-2G	FRN0040E3□-2G	FRN0056E3□-2G	ACR2-15A										
5.5(7.5)		FRN0040E3□-2G	FRN0056E3□-2G	FRN0056E3□-2G	FRN0069E3□-2G	ACR2-18.5A										
7.5(10)		FRN0056E3□-2G	FRN0069E3□-2G	FRN0069E3□-2G	FRN0088E3□-2G	ACR2-22A										
11(15)		FRN0069E3□-2G	FRN0088E3□-2G	FRN0088E3□-2G	FRN0115E3□-2G	ACR2-37										
15(20)		FRN0088E3□-2G	FRN0115E3□-2G	FRN0115E3□-2G	—	—										
18.5(25)		FRN0115E3□-2G	—	—	—	—										
22(30)		—	—	—	—	—										
30(40)		—	—	—	—	—										
1-phase 200V Note1)	0.1(1/8)	—	—	—	FRN0001E3S-7G	ACR2-0.4A	A	120	90	65	20	M5 (6×10)	115	M4	1.4	
	0.2(1/4)	FRN0001E3S-7G	FRN0002E3S-7G	FRN0002E3S-7G	FRN0004E3S-7G	ACR2-0.75A										
	0.4(1/2)	FRN0002E3S-7G	FRN0004E3S-7G	FRN0004E3S-7G	—	ACR2-1.5A										
	0.55(3/4)	—	FRN0006E3S-7G	FRN0006E3S-7G	—	ACR2-2.2A										
	0.75(1)	—	FRN0006E3S-7G	—	FRN0010E3S-7G	ACR2-3.7A										
	1.1(1.5)	FRN0006E3S-7G	—	—	FRN0012E3S-7G	ACR2-5.5A										
	1.5(2)	—	FRN0010E3S-7G	FRN0012E3S-7G	—	—										
	2.2(3)	FRN0010E3S-7G	FRN0012E3S-7G	FRN0012E3S-7G	—	—										
	3.0(4)	FRN0012E3S-7G	—	—	—	—										

*The □ in the above inverter type indicates the symbol for each type.

Note) It is not necessary to use the reactor unless a particularly stable power supply is required, i.e., DC bus connection operation (PN connection operation).

Use the DC reactor (DCR) as a measure against harmonics.

Note1) EMC filter built-in type is only available in HHD specification.

Zero-phase reactor for reducing radiated noise [ACL-40C, ACL-74C]

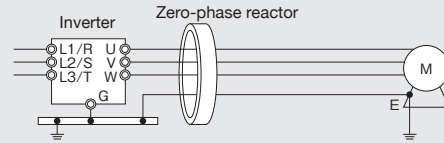

● **ACL-40C**

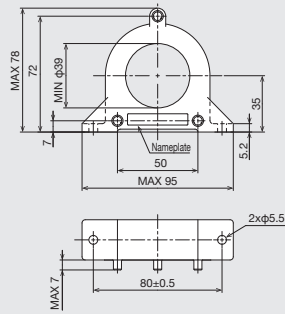

● **ACL-74C**

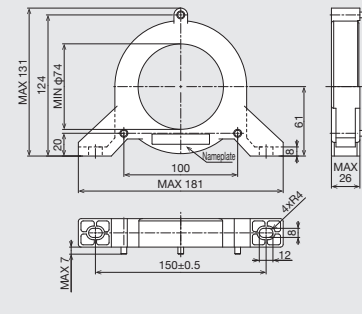

Applied wire size list

Type	Q'ty	No. of turns	Recommended wire size [mm ²] Note
ACL-40C	1	4	2.0, 3.5, 5.5
	2	2	8, 14
ACL-74C	1	4	8, 14
	2	2	22, 38, 60, 5.5×2, 8×2, 14×2, 22×2
	4	1	100, 150, 200, 250, 38×2, 60×2, 100×2

NOTE) Use a 600V HIV insulation cable (Allowable temp. 75°C).

Output circuit filter (OFL-□□□-4A)



Filter dimensions (22kW or less)

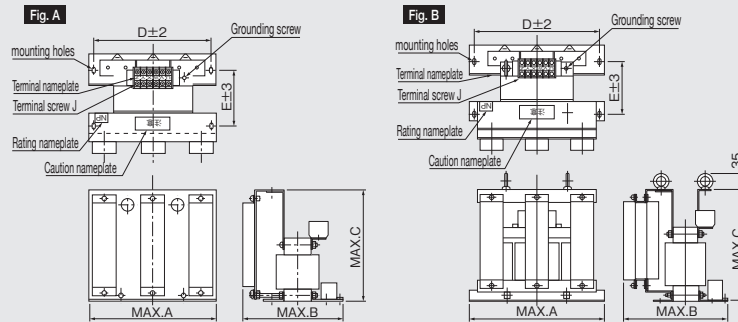

Filter dimensions (30kW or more):reactor

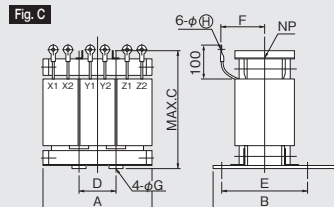

<OFL-□□□-4A>

- Suppresses the surge voltage (micro surge) generated at the motor connection end.
- Suppresses the high-frequency leakage current between wires to prevent overheating and overcurrent tripping in the inverter.
- There are no carrier frequency limitations.
- Can also be applied to vector control inverters (auto-tuning is possible).

Type	Fig	Dimensions [mm]								Approx. weight [kg]				
		A	B	C	D	E	F	I	Grounding screw	Terminal screw H	Terminal screw (G: mounting hole)	Filter	Reactor	Resistor and capacitor
3-phase 400V	A	220	175	195	200	95			M4	M4	M5	7		
			225	220		115						14		
		290	290	230	260	160			M5	M5	M6	22		
	B	330	275	310	300	145			M6	M6	M8	35		
			300	330		170						45		
		210	175	210	70	140	90	160		6.4	8		12	3

* This filter is not limited by carrier frequency.

To all our customers who purchase Fuji Electric products included in this catalog:

Please take the following items into consideration when placing your order.

When requesting an estimate and placing your orders for the products included in these materials, please be aware that any items such as specifications which are not specifically mentioned in the contract, catalog, specifications or other materials will be as mentioned below.
In addition, the products included in these materials are limited in the use they are put to and the place where they can be used, etc., and may require periodic inspection. Please confirm these points with your sales representative or directly with this company.
Furthermore, regarding purchased products and delivered products, we request that you take adequate consideration of the necessity of rapid receiving inspections and of product management and maintenance even before receiving your products.

1. Free of Charge Warranty Period and Warranty Range

1-1 Free of charge warranty period

- (1) The product warranty period is "1 year from the date of purchase" or 24 months from the manufacturing date imprinted on the name plate, whichever date is earlier.
- (2) However, in cases where the operating environment, conditions of use, use frequency and times used, etc., have an effect on product life, this warranty period may not apply.
- (3) Furthermore, the warranty period for parts restored by Fuji Electric's Service Department is "6 months from the date that repairs are completed."

1-2 Warranty range

- (1) In the event that breakdown occurs during the product's warranty period which is the responsibility of Fuji Electric, Fuji Electric will replace or repair the part of the product that has broken down free of charge at the place where the product was purchased or where it was delivered. However, if the following cases are applicable, the terms of this warranty may not apply.
 - 1) The breakdown was caused by inappropriate conditions, environment, handling or use methods, etc. which are not specified in the catalog, operation manual, specifications or other relevant documents.
 - 2) The breakdown was caused by the product other than the purchased or delivered Fuji's product.
 - 3) The breakdown was caused by the product other than Fuji's product, such as the customer's equipment or software design, etc.
 - 4) Concerning the Fuji's programmable products, the breakdown was caused by a program other than a program supplied by this company, or the results from using such a program.
 - 5) The breakdown was caused by modifications or repairs affected by a party other than Fuji Electric.
 - 6) The breakdown was caused by improper maintenance or replacement using consumables, etc. specified in the operation manual or catalog, etc.
 - 7) The breakdown was caused by a chemical or technical problem that was not foreseen when making practical application of the product at the time it was purchased or delivered.
 - 8) The product was not used in the manner the product was originally intended to be used.
 - 9) The breakdown was caused by a reason which is not this company's responsibility, such as lightning or other disaster.
- (2) Furthermore, the warranty specified herein shall be limited to the purchased or delivered product alone.
- (3) The upper limit for the warranty range shall be as specified in item (1) above and any damages (damage to or loss of machinery or equipment, or lost profits from the same, etc.) consequent to or resulting from breakdown of the purchased or delivered product shall be excluded from coverage by this warranty.

1-3. Trouble diagnosis

As a rule, the customer is requested to carry out a preliminary trouble diagnosis. However, at the customer's request, this company or its service network can perform the trouble diagnosis on a chargeable basis. In this case, the customer is asked to assume the burden for charges levied in accordance with this company's fee schedule.

2. Exclusion of Liability for Loss of Opportunity, etc.

Regardless of whether a breakdown occurs during or after the free of charge warranty period, this company shall not be liable for any loss of opportunity, loss of profits, or damages arising from special circumstances, secondary damages, accident compensation to another company, or damages to products other than this company's products, whether foreseen or not by this company, which this company is not be responsible for causing.

3. Repair Period after Production Stop, Spare Parts Supply Period (Holding Period)

Concerning models (products) which have gone out of production, this company will perform repairs for a period of 7 years after production stop, counting from the month and year when the production stop occurs. In addition, we will continue to supply the spare parts required for repairs for a period of 7 years, counting from the month and year when the production stop occurs. However, it is estimated that the life cycle of certain electronic and other parts is short and it will be difficult to procure or produce those parts, so there may be cases where it is difficult to provide repairs or supply spare parts even within this 7-year period. For details, please confirm at our company's business office or our service office.

4. Transfer Rights

In the case of standard products which do not include settings or adjustments in an application program, the products shall be transported to and transferred to the customer and this company shall not be responsible for local adjustments or trial operation.

5. Service Contents

The cost of purchased and delivered products does not include the cost of dispatching engineers or service costs. Depending on the request, these can be discussed separately.

6. Applicable Scope of Service

Above contents shall be assumed to apply to transactions and use of the country where you purchased the products. Consult the local supplier or Fuji for the detail separately.

MEMO

Area with horizontal dashed lines for writing notes.

Features
Main application examples
Model variations
Type number nomenclature
Standard specifications
Common specifications
Terminal specifications
Basic wiring diagram
External dimensions
Keypad
Function codes
Options
Product warranty



NOTES

When running general-purpose motors

- **Driving a 400V general-purpose motor**
When driving a 400V general-purpose motor with an inverter using extremely long cables, damage to the insulation of the motor may occur. Use an output circuit filter (OFL) if necessary after checking with the motor manufacturer. Fuji's motors do not require the use of output circuit filters because of their reinforced insulation.
- **Torque characteristics and temperature rise**
When the inverter is used to run a general-purpose motor, the temperature of the motor becomes higher than when it is operated using a commercial power supply. In the low-speed range, the cooling effect will be weakened, so decrease the output torque of the motor. If constant torque is required in the low-speed range, use a Fuji inverter motor or a motor equipped with an externally powered ventilating fan.
- **Vibration**
When the motor is mounted to a machine, resonance may be caused by the natural frequencies, including that of the machine. Operation of a 2-pole motor at 60Hz or more may cause abnormal vibration.
* Study use of tier coupling or dampening rubber.
* It is also recommended to use the inverter jump frequency control to avoid resonance points.
- **Noise**
When an inverter is used with a general-purpose motor, the motor noise level is higher than that with a commercial power supply. To reduce noise, raise carrier frequency of the inverter. High-speed operation at 60Hz or more can also result in more noise.

When running special motors

- **High-speed motors**
When driving a high-speed motor while setting the frequency higher than 120Hz, test the combination with another motor to confirm the safety of high-speed motors.
- **Explosion-proof motors**
When driving an explosion-proof motor with an inverter, use a combination of a motor and an inverter that has been approved in advance.
- **Submersible motors and pumps**
These motors have a larger rated current than general-purpose motors. Select an inverter whose rated output current is greater than that of the motor.
These motors differ from general-purpose motors in thermal characteristics. Set a low value in the thermal time constant of the motor when setting the electronic thermal function.
- **Brake motors**
For motors equipped with parallel-connected brakes, their braking power must be supplied from the primary circuit (commercial power supply). If the brake power is connected to the inverter power output circuit (secondary circuit) by mistake, problems may occur.
Do not use inverters for driving motors equipped with series-connected brakes.
- **Geared motors**
If the power transmission mechanism uses an

oil-lubricated gearbox or speed changer/reducer, then continuous motor operation at low speed may cause poor lubrication. Avoid such operation.

- **Synchronous motors**
It is necessary to use software suitable for this motor type. Contact Fuji for details.
- **Single-phase motors**
Single-phase motors are not suitable for inverter-driven variable speed operation. Use three-phase motors.
* Even if a single-phase power supply is available, use a three-phase motor as the inverter provides three-phase output.

Environmental conditions

- **Installation location**
Use the inverter in a location with an ambient temperature range of -10 to 50°C.
The inverter and braking resistor surfaces become hot under certain operating conditions. Install the inverter on nonflammable material such as metal. Ensure that the installation location meets the environmental conditions specified in "Environment" in inverter specifications.

Combination with peripheral devices

- **Installing a molded case circuit breaker (MCCB)**
Install a recommended molded case circuit breaker (MCCB) or an earth leakage circuit breaker (ELCB) in the primary circuit of each inverter to protect the wiring. Ensure that the circuit breaker capacity is equivalent to or lower than the recommended capacity.
- **Installing a magnetic contactor (MC) in the output (secondary) circuit**
If a magnetic contactor (MC) is mounted in the inverter's secondary circuit for switching the motor to commercial power or for any other purpose, ensure that both the inverter and the motor are fully stopped before you turn the MC on or off. Remove the surge killer integrated with the MC.
- **Installing a magnetic contactor (MC) in the input (primary) circuit**
Do not turn the magnetic contactor (MC) in the primary circuit on or off more than once an hour as an inverter fault may result. If frequent starts or stops are required during motor operation, use FWD/REV signals.
- **Protecting the motor**
The electronic thermal function of the inverter can protect the motor. The operation level and the motor type (general-purpose motor, inverter motor) should be set. For high-speed motors or water-cooled motors, set a small value for the thermal time constant to protect the motor.
If you connect the motor thermal relay to the motor with a long cable, a high-frequency current may flow into the wiring stray capacitance. This may cause the relay to trip at a current lower than the set value for the thermal relay. If this happens, lower the carrier frequency or use the output circuit filter (OFL).
- **Regarding power-factor correcting capacitor**
Do not mount power factor correcting capacitors in the inverter (primary) circuit. Use the DC REACTOR to improve the inverter power factor. Do

not use power factor correcting capacitors in the inverter output circuit (secondary). An overcurrent trip will occur, disabling motor operation.

- **Discontinuance of surge killer**
Do not mount surge killers in the inverter output (secondary) circuit.
- **Reducing noise**
Use of a filter and shielded wires are typical measures against noise to ensure that EMC Directives are met.
- **Measures against surge currents**
If an overvoltage trip occurs while the inverter is stopped or operated under a light load, it is assumed that the surge current is generated by open/close of the phase-advancing capacitor in the power system.
We recommend connecting a DC REACTOR to the inverter.
- **Megger test**
When checking the insulation resistance of the inverter, use a 500V megger and follow the instructions contained in the Instruction Manual.

Wiring

- **Wiring distance of control circuit**
When performing remote operation, use twisted shield wire and limit the distance between the inverter and the control box to 20m.
- **Wiring length between inverter and motor**
If long wiring is used between the inverter and the motor, the inverter will overheat or trip as a result of overcurrent (high-frequency current flowing into the stray capacitance) in the wires connected to the phases. Ensure that the wiring is shorter than 50m. If this length must be exceeded, lower the carrier frequency or mount an output circuit filter (OFL).
- **Wiring size**
Select cables with a sufficient capacity by referring to the current value or recommended wire size.
- **Wiring type**
Do not use multicore cables that are normally used for connecting several inverters and motors.
- **Grounding**
Securely ground the inverter using the grounding terminal.

Selecting inverter capacity

- **Driving general-purpose motor**
Select an inverter according to the applicable motor ratings listed in the standard specifications table for the inverter. When high starting torque is required or quick acceleration or deceleration is required, select an inverter with a capacity one size greater than the standard.
- **Driving special motors**
Select an inverter that meets the following condition:
Inverter rated current > Motor rated current.

Transportation and storage

When transporting or storing inverters, follow the procedures and select locations that meet the environmental conditions that agree with the inverter specifications.